

Introduction to OSPF



Dev Jeenia

Routing and Forwarding

- Routing is not the same as Forwarding
- Routing is the building of maps
 - Each routing protocol usually has its own routing database
 - Routing protocols populate the forwarding table
- Forwarding is passing the packet to the next hop device
 - Forwarding table contains the best path to the next hop for each prefix
 - There is only ONE forwarding table

OSPF Background

- ❑ Developed by IETF – RFC1247
 - Designed for Internet TCP/IP environment
- ❑ OSPF v2 described in RFC2328/STD54
 - For IPv4 only
- ❑ OSPF v3 described in RFC2740
 - Mainly for IPv6
 - Supports the IPv4 address family also
- ❑ Link state/Shortest Path First Technology
- ❑ Dynamic Routing
- ❑ Fast Convergence
- ❑ Route authentication

Link State Algorithm

- Each router contains a database containing a map of the whole topology
 - Links
 - Their state (including cost)
- All routers have the same information
- All routers calculate the best path to every destination
- Any link state changes are flooded across the network
 - “Global spread of local knowledge”

Link State Routing

- Automatic neighbour discovery
 - Neighbours are physically connected routers
 - OSPF runs over IP
- Each router constructs a Link State Packet (LSP)
 - Distributes the LSP to neighbours...
 - ...using an LSA (Link State Advertisements)
- Each router computes its best path to every destination
- On network failure
 - New LSPs are flooded
 - All routers recompute routing table

Low Bandwidth Requirements

- Only changes are propagated
- Multicast used on multi-access broadcast networks
 - 224.0.0.5 used for all OSPF speakers
 - 224.0.0.6 used for DR and BDR routers

“Shortest Path First”

The optimal path is determined by the sum of the interface costs

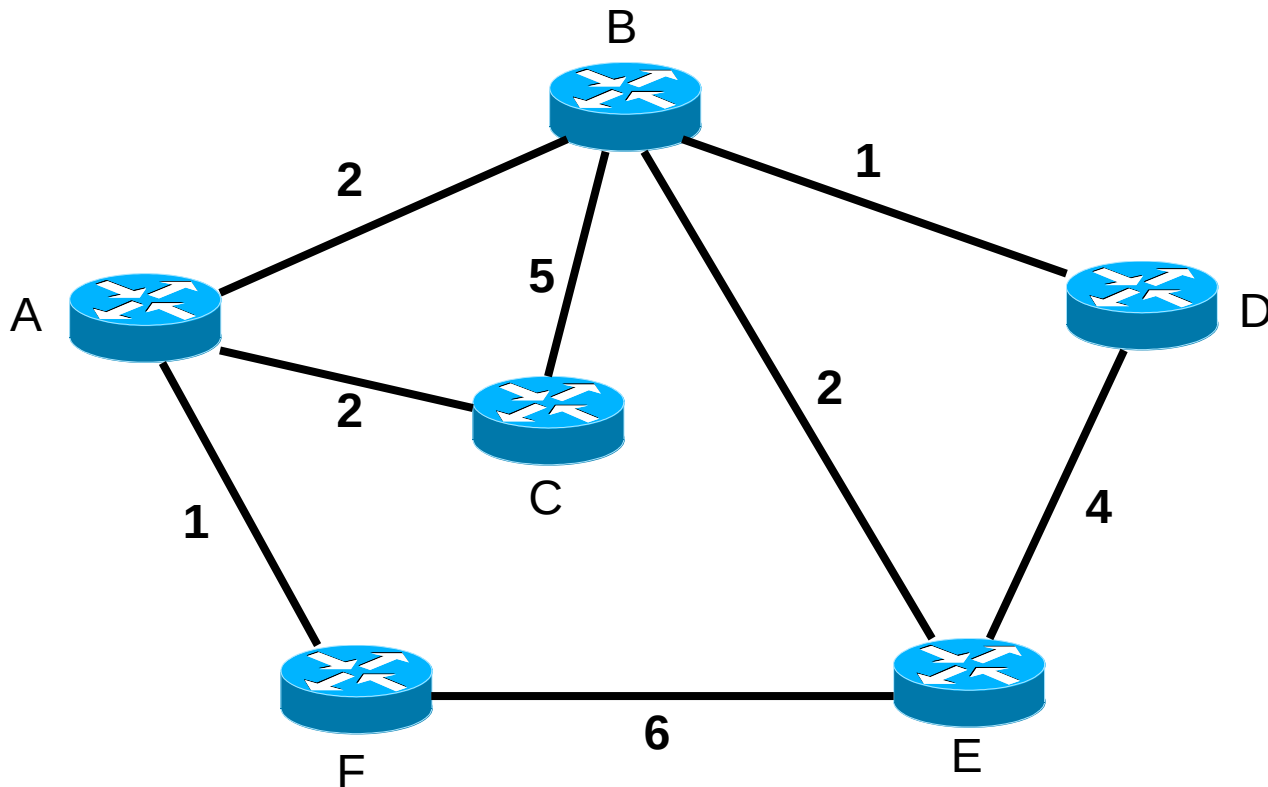

“Shortest Path First”

Each router computes its best path to every destination

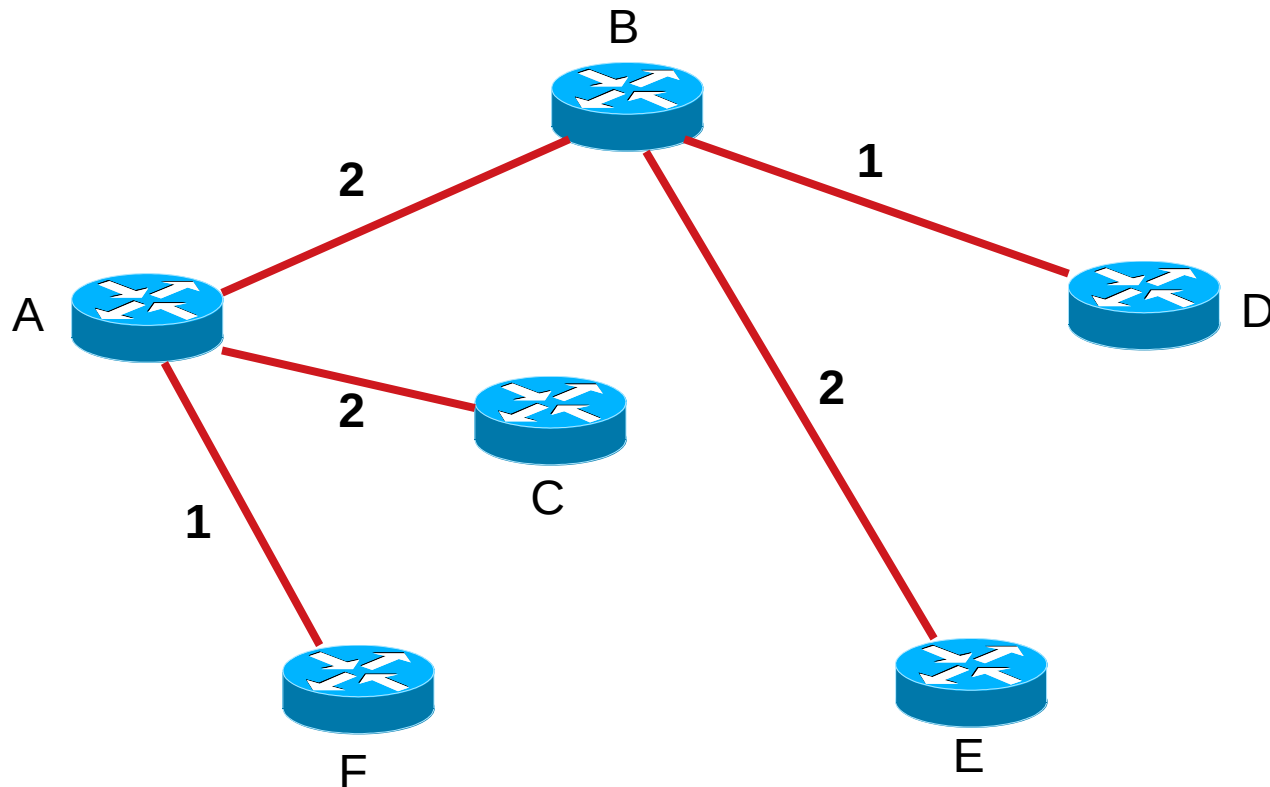

OSPF: How it works

□ Hello Protocol

- Responsible for establishing and maintaining neighbour relationships
- Elects Designated Router on broadcast networks

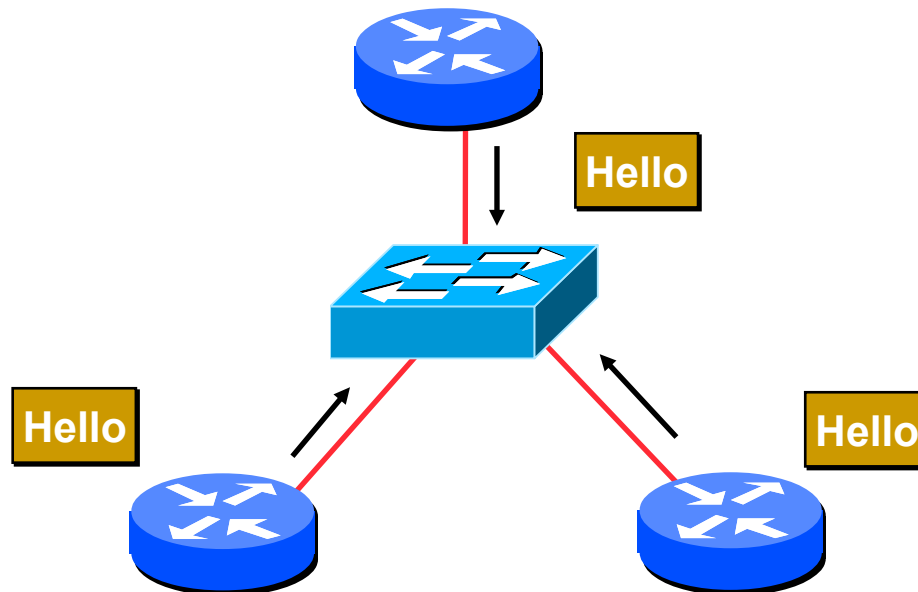

OSPF: How it works

- Hello Protocol
 - Hello Packets sent periodically on all OSPF enabled interfaces
 - Adjacencies formed between **some** neighbours
- Hello Packet
 - Contains information like Router Priority, Hello Interval, a list of known neighbours, Router Dead Interval, and the network mask

OSPF: How it works

- Trade Information using LSAs
 - LSAs are added to the OSPF database
 - LSAs are passed on to OSPF neighbours
- Each router builds an identical link state database
- SPF algorithm run on the database
- Forwarding table built from the SPF tree
- OSPF uses the Djikstra Algorithm

OSPF: How it works

- When change occurs:
 - Announce the change to all OSPF neighbours
 - All routers run the SPF algorithm on the revised database
 - Install any change in the forwarding table

Broadcast Networks

- Introduces Designated and Backup Designated routers (DR and BDR)
 - Only DR and BDR form full adjacencies with other routers
 - The remaining routers remain in a “2-way” state with each other
 - If they were adjacent, we’d have n-squared scaling problem
 - If DR or BDR “disappear”, re-election of missing router takes place

Designated Router

- One per multi-access network
 - Generates network link advertisements for the multi-access network
 - Speeds database synchronisation

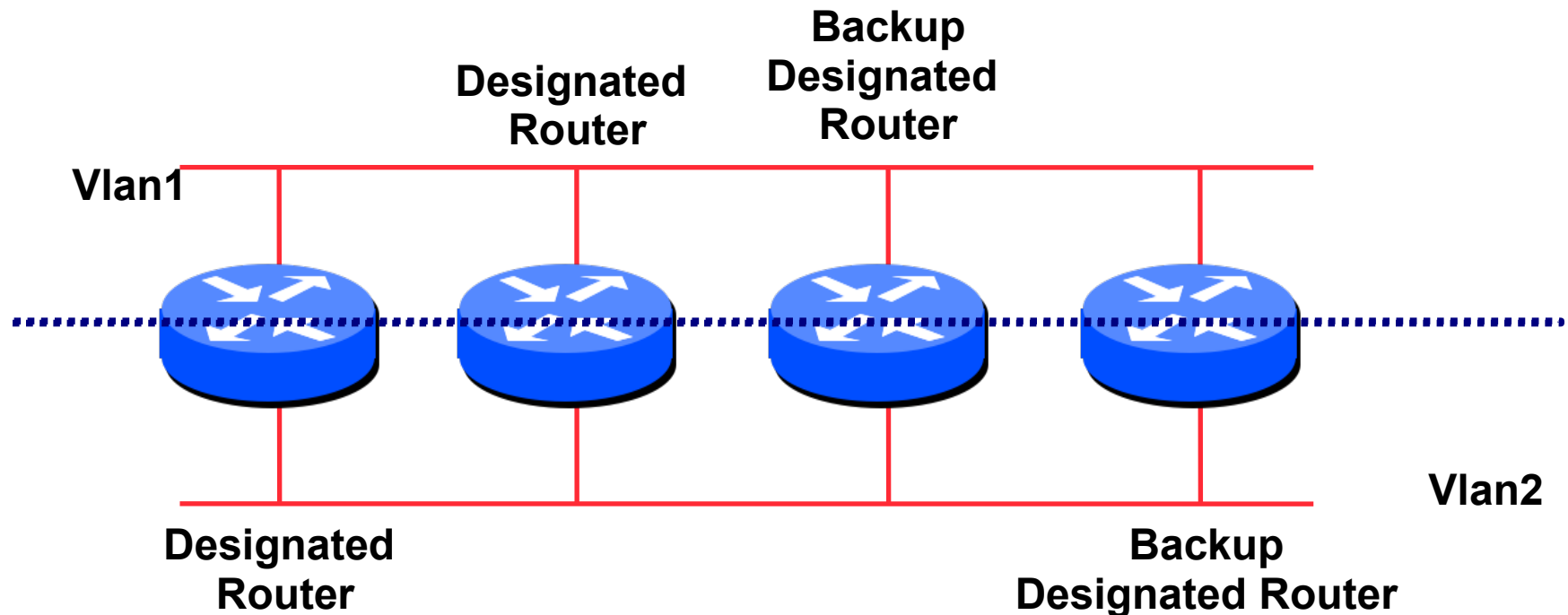

Designated Router

- All routers are adjacent to the DR
 - All routers are adjacent to the BDR also
- All routers exchange routing information with DR
 - All routers exchange routing information with the BDR
- DR updates the database of all its neighbours
 - BDR updates the database of all its neighbours
- This scales! $2n$ problem rather than having an n -*squared* problem.

Designated Router

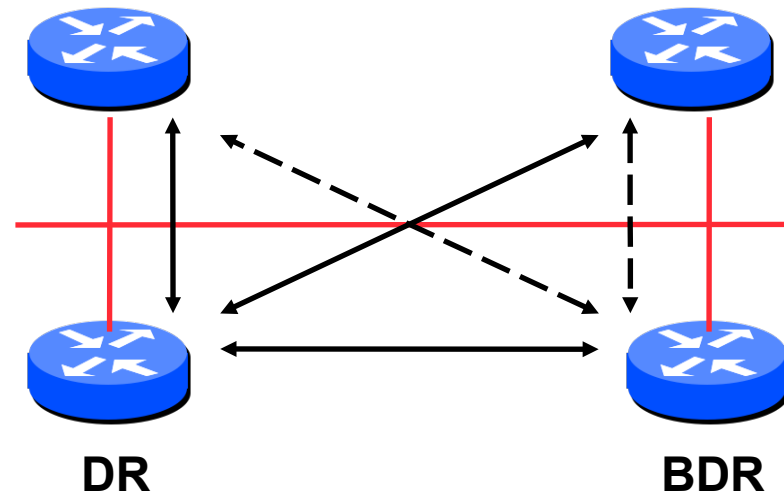

- ❑ Adjacencies only formed with DR and BDR
- ❑ LSAs propagate along the adjacencies

Designated Router Priority

- Determined by interface priority
- Otherwise by highest router ID
 - (For Cisco IOS, this is address of loopback interface, otherwise highest IP address on router)

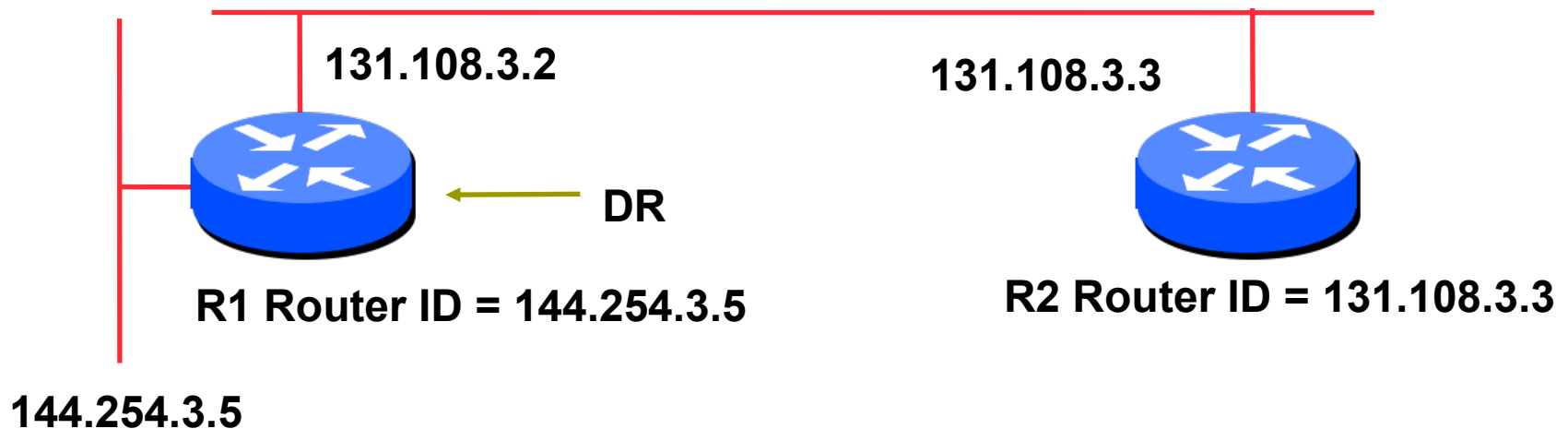

More Advanced OSPF

- OSPF Areas
- Router Classification
- OSPF route types
- Route authentication
- Equal cost multipath

OSPF Areas

- Group of contiguous hosts and networks
- Per area topological database
 - Invisible outside the area
 - Reduction in routing traffic
- Backbone area contiguous
 - All other areas must be connected to the backbone
- Virtual Links

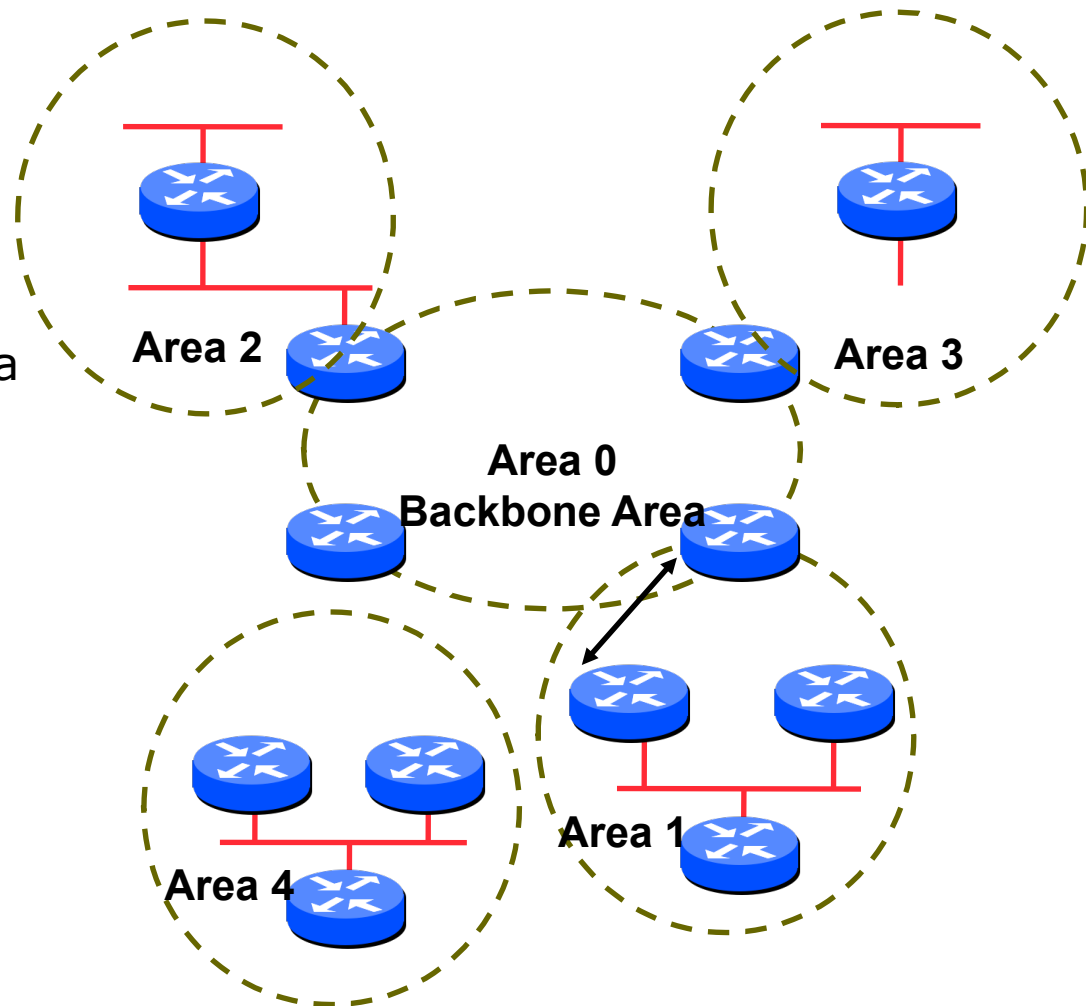

OSPF Areas

- Reduces routing traffic in area 0
- Consider subdividing network into areas
 - Once area 0 is more than 30+ routers (though areas with 200+ routers in an area are known to work fine)
 - Once area 0 topology starts getting complex
 - Less often today but when a group of routers is over an expensive small link e.g vsat
- Area design often mimics typical ISP core network design
- Virtual links are used for “awkward” connectivity topologies (...) **please do not use these.**

Classification of Routers

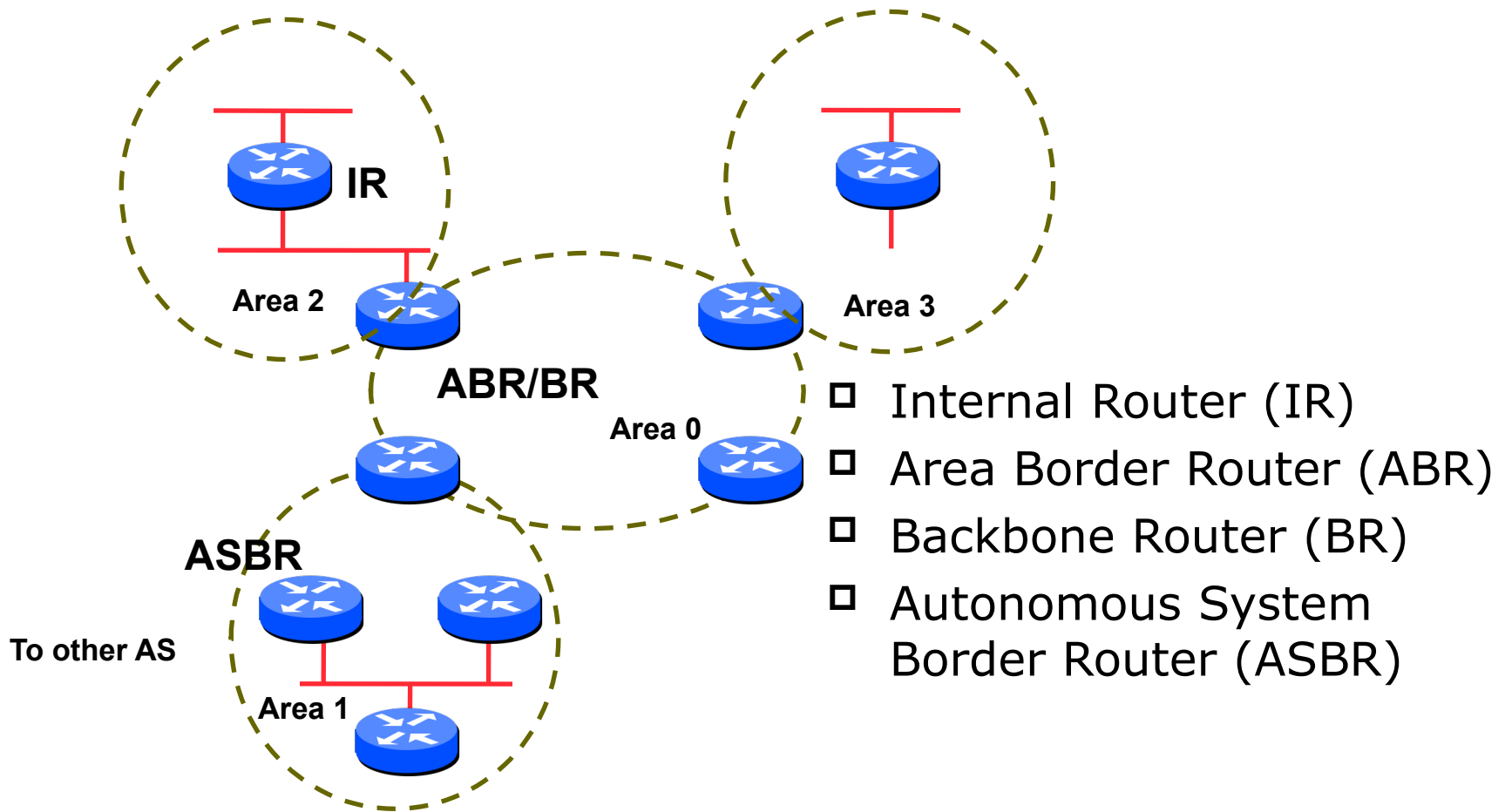

OSPF Route Types

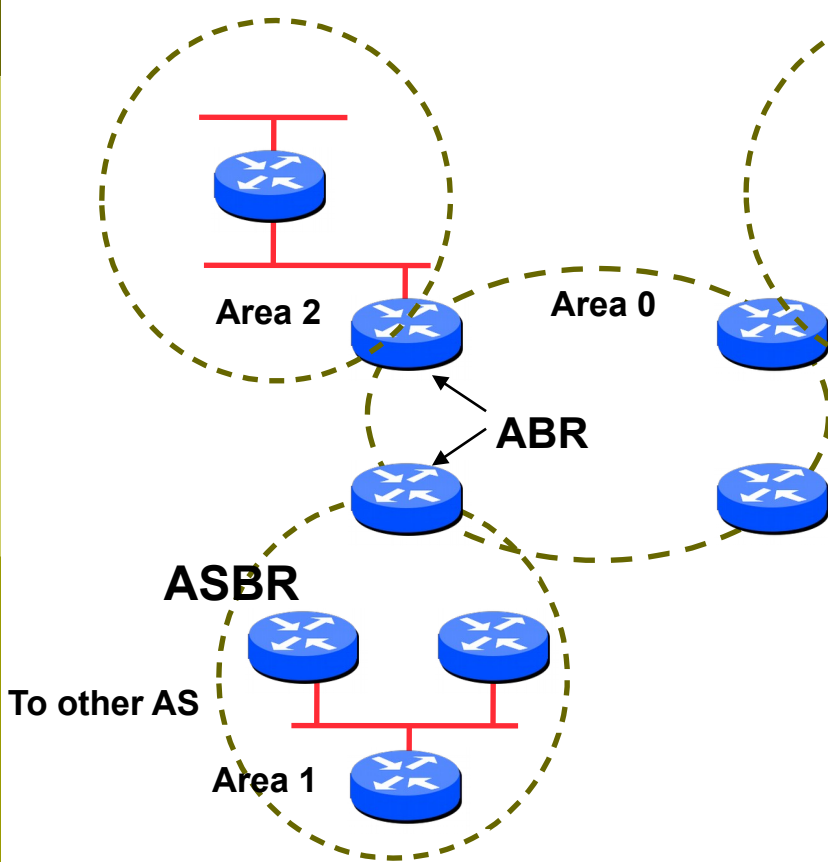

- Intra-Area route
 - All routes inside an area
- Inter-Area route
 - Routes advertised from one area to another area by an ABR
- External route
 - Routes imported into OSPF from another routing protocol by an ASBR

Route Authentication

- Now recommended to use route authentication for OSPF
 - ... and all other routing protocols
- Susceptible to denial of service attacks
 - OSPF runs on TCP/IP
 - Automatic neighbour discovery
- Route authentication – Cisco example:

```
router ospf <pid>
  network 192.0.2.0 0.0.0.255 area 0
  area 0 authentication
interface ethernet 0/0
  ip ospf authentication-key <password>
```

Equal Cost Multipath

- If n paths to same destination have equal cost, OSPF will install n entries in the forwarding table
 - Loadsharing over the n paths
 - Useful for expanding links across an ISP backbone
 - Don't need to use hardware multiplexors
 - Don't need to use static routing

Summary

- Link State Protocol
- Shortest Path First
- OSPF operation
- Broadcast networks
 - Designated and Backup Designated Router
- Advanced Topics
 - Areas, router classification, external networks, authentication, multipath

OSPFv3



OSPFv3 overview

- OSPF for IPv6
- Based on OSPFv2, with enhancements
- Distributes IPv6 prefixes
- Runs directly over IPv6
- “Ships in the night” with OSPFv2
- Can distribute IPv4 prefixes (if supported)

OSPFv3 / OSPFv2

Similarities

- Basic packet types
 - Hello, DBD, LSR, LSU, LSA
- Mechanisms for neighbor discovery and adjacency formation
- Interface types
 - P2P, P2MP, Broadcast, NBMA, Virtual
- LSA flooding and ageing
- Nearly identical LSA types

v2, v3 Differences

OSPFv3 runs on a Link instead of per IP Subnet

- A link by definition is a medium over which two nodes can communicate at link layer
- In IPv6 multiple IP subnets can be assigned to a link and two nodes in different subnets can communicate over this link. Therefore, OSPFv3 runs per link instead of per IP subnet.

v2, v3 Differences (Cont.)

Separation of prefix & topology information

- ❑ OSPFv2 carries IP address information in Type 1 & Type 2 LSA's.
- ❑ Makes routers announce both their IP addresses and topology information in the same LSA's.
- ❑ A change in an IP address means a Type 1 LSA is originated. But because Type 1 LSA's also carry topology information, a full SPF is run in the local OSPF area – unnecessary; only IP address is affected.
- ❑ So only Type 3, 4, 5 and 7 LSA's trigger PRC in OSPFv2, as their only purpose is to signal prefix information (external areas).

v2, v3 Differences (Cont.)

Generalization of Flooding Scope

- In OSPFv3 there are three flooding scope for LSAs (link-local scope, area scope, AS scope) and they are coded in LS type explicitly
- In OSPFv2 initially only area and AS wide flooding was defined; later opaque LSAs introduced link local scope as well

v2, v3 Differences (Cont.)

Explicit Handling of Unknown LSA

- ❑ The handling of unknown LSA is coded via U-bit in LS type
- ❑ When U bit is set, the LSA is flooded with the corresponding flooding scope, as if it was understood
- ❑ When U bit is clear, the LSA is flooded with link local scope
- ❑ In v2 unknown LSA were discarded

v2, v3 Differences (Cont.)

Authentication is Removed from OSPF

- Authentication in OSPFv3 has been removed
 - OSPFv3 relies on IPv6 authentication header since OSPFv3 runs over IPv6
- AuthType and Authentication field in the OSPF packet header have been suppressed
- AH (Authentication Header) provides authentication
- ESP (Encapsulating Security Payload) provides encryption & integrity
- ESP, if used alone, provides both authentication and encryption
- AH supported from 12.3T
- ESP supported from 12.4T

v2, v3 Differences (Cont.)

OSPF Packet format has been changed

- ❑ The mask field has been removed from Hello packet
- ❑ IPv6 prefix is only present in payload of Link State update packet

Configuring OSPFv3 in Cisco IOS

- Similar to OSPFv2
 - Prefixing existing Interface and Exec mode commands with `"ipv6"`
- Interfaces configured directly
 - Replaces `network` command
 - (Also available in OSPFv2 from IOS 12.4 and most recent 12.0S and 12.2SB, 12.2SR releases).
 - (Called the "Area Command in Interface Mode for OSPFv2" feature).
- "Native" IPv6 router mode
 - Not a sub-mode of `router ospf`

Configuration modes in OSPFv3

- ▣ Entering router mode

```
[no] ipv6 router ospf <process ID>
```

- ▣ Entering interface mode

```
[no] ipv6 ospf <process ID> area <area ID>
```

- ▣ Exec mode

```
show ipv6 ospf [<process ID>]
```

```
clear ipv6 ospf [<process ID>]
```

OSPFv3 Specific Attributes

- IOS

❑ Configuring area range

```
[no] area <area ID> range <prefix>/<prefix length>
```

❑ Showing new LSA

```
show ipv6 ospf [<process ID>] database link
```

```
show ipv6 ospf [<process ID>] database prefix
```

❑ Configuring authentication

■ Under ipv6 router ospf:

```
area 0 authentication ipsec spi 256 md5 <passwd>
```

■ Under interface:

```
ipv6 ospf authentication ipsec spi 256 md5 <passwd>
```

OSPFv3 Configuration Example

```
Router1#  
interface POS1/1  
  ipv6 address 2001:db8:ffff:1::1/64  
  ipv6 ospf 100 area 0  
!  
interface POS2/0  
  ipv6 address 2001:db8:1:1::2/64  
  ipv6 ospf 100 area 1  
!  
ipv6 router ospf 100
```

```
Router2#  
interface POS3/0  
  ipv6 address 2001:db8:1:1::1/64  
  ipv6 ospf 100 area 1  
!  
ipv6 router ospf 100
```

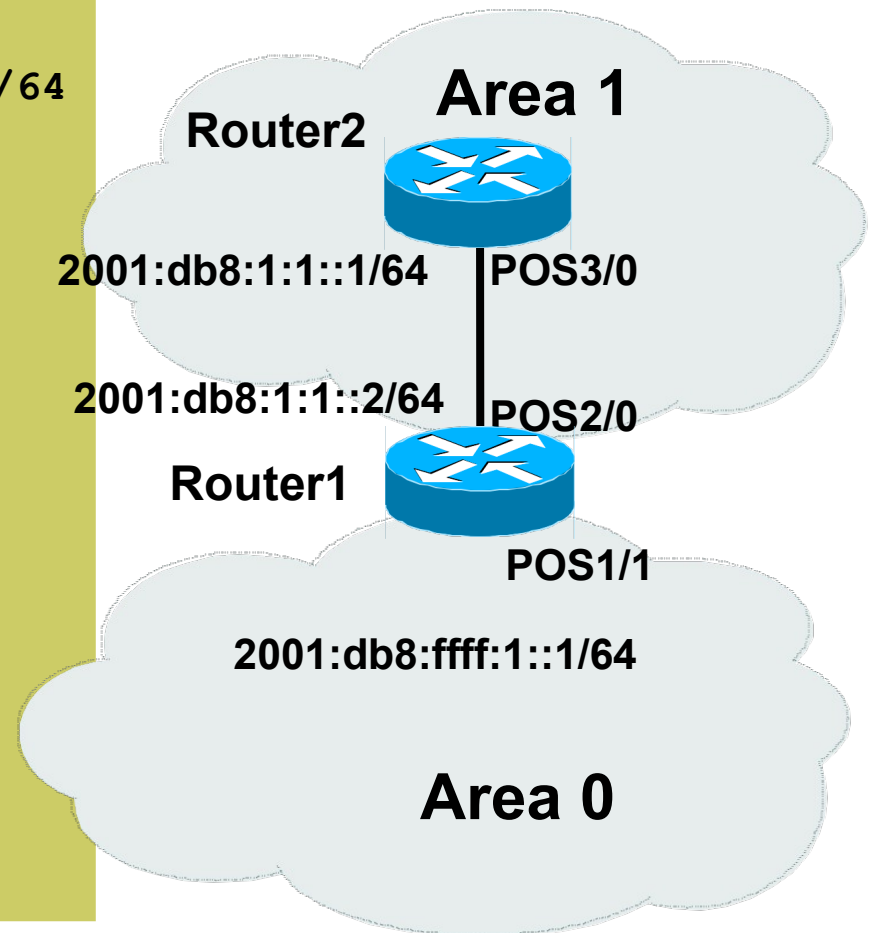

OSPFv3 entries in Routing Table

```
Router2#sh ipv6 route
```

```
IPv6 Routing Table - 5 entries
```

```
Codes: C - Connected, L - Local, S - Static, R - RIP, B - BGP
```

```
U - Per-user Static route
```

```
I1 - ISIS L1, I2 - ISIS L2, IA - ISIS interarea
```

```
O - OSPF intra, OI - OSPF inter, OE1 - OSPF ext 1, OE2 - OSPF ext 2
```

```
OI 2001:db8:FFFF:1::/64 [110/2]  
   via FE80::2D0:FFFF:FE60:DFFF, POS3/0
```

```
C 2001:db8:1:1::/64 [0/0]  
   via ::, POS3/0
```

```
L 2001:db8:1:1::1/128 [0/0]  
   via ::, POS3/0
```

```
L FE80::/10 [0/0]  
   via ::, Null0
```

```
L FF00::/8 [0/0]  
   via ::, Null0
```

OSPFv3 on IPv6 Tunnels over IPv4

On Router1:

```
interface Tunnel0
no ip address
ipv6 address 2001:db8:1::1/64
ipv6 router ospf 1 area 0
tunnel source 10.42.1.1
tunnel destination 10.42.2.1
tunnel mode ipv6ip
!
ipv6 router ospf 1
```

On Router2:

```
interface Tunnel0
no ip address
ipv6 address 2001:db8:1::2/64
ipv6 router ospf 1 area 0
tunnel source 10.42.2.1
tunnel destination 10.42.1.1
tunnel mode ipv6ip
!
ipv6 router ospf 1
```

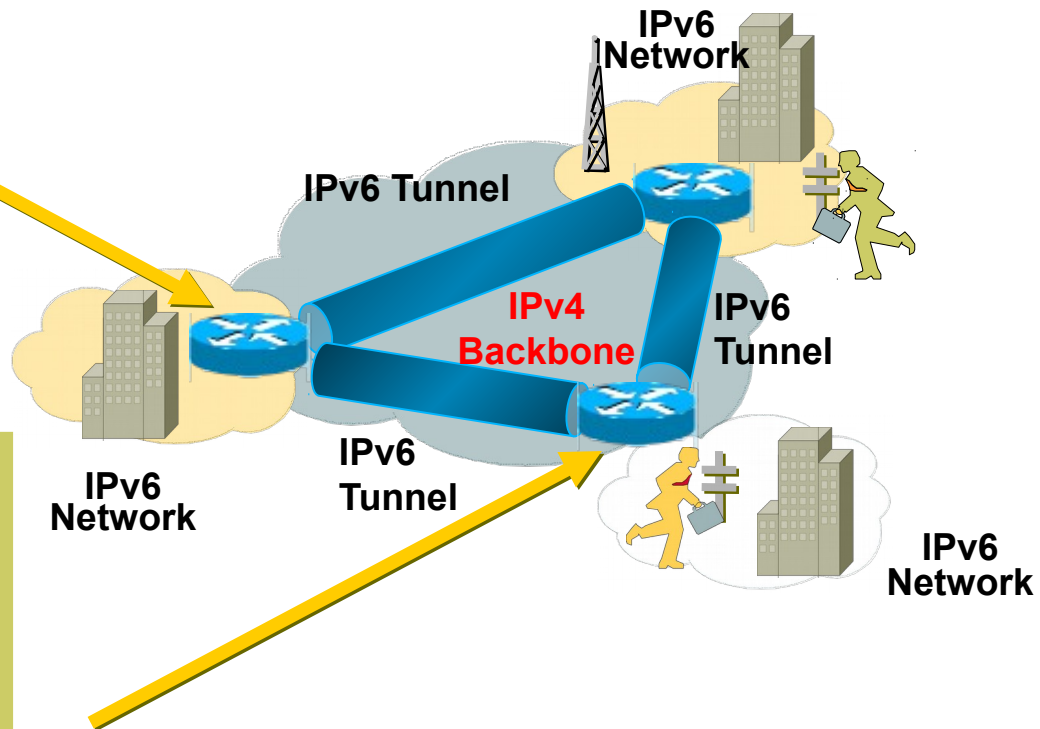

Introduction to OSPF



Questions?