

Static Routing Exercise



Scalable Infrastructure
Workshop

What will the exercise involve?

- ❑ Unix network interface configuration
- ❑ Cisco network interface configuration
- ❑ Static routes
- ❑ Default route
- ❑ Testing

Routing

- ❑ Routing is done based on destination IP address
- ❑ Without routing, an interface can only reach destinations that are on their local network segment.
- ❑ A device with at least 2 interfaces can route

Routing

❑ Static route

- specifically instructs router on which route to take to a particular destination network. This will almost always override anything else that the router knows.

❑ Dynamic route

- learnt via routing protocols implemented on routers

❑ Default route

- route that instructs a machine where to send packets for destinations that are not in the routing table. This is usually the 'last resort' that a router will take.

Static Routing

□ Advantages

- Simple to configure and maintain
- Secure as only defined routes can be accessed
- Bandwidth is not used for sending routing updates

□ Disadvantages

- Manual update of routes after changes
- Explicit addition of routes for all networks
- Potential for configuration mistakes

IP Routing Configuration

Static/default route example

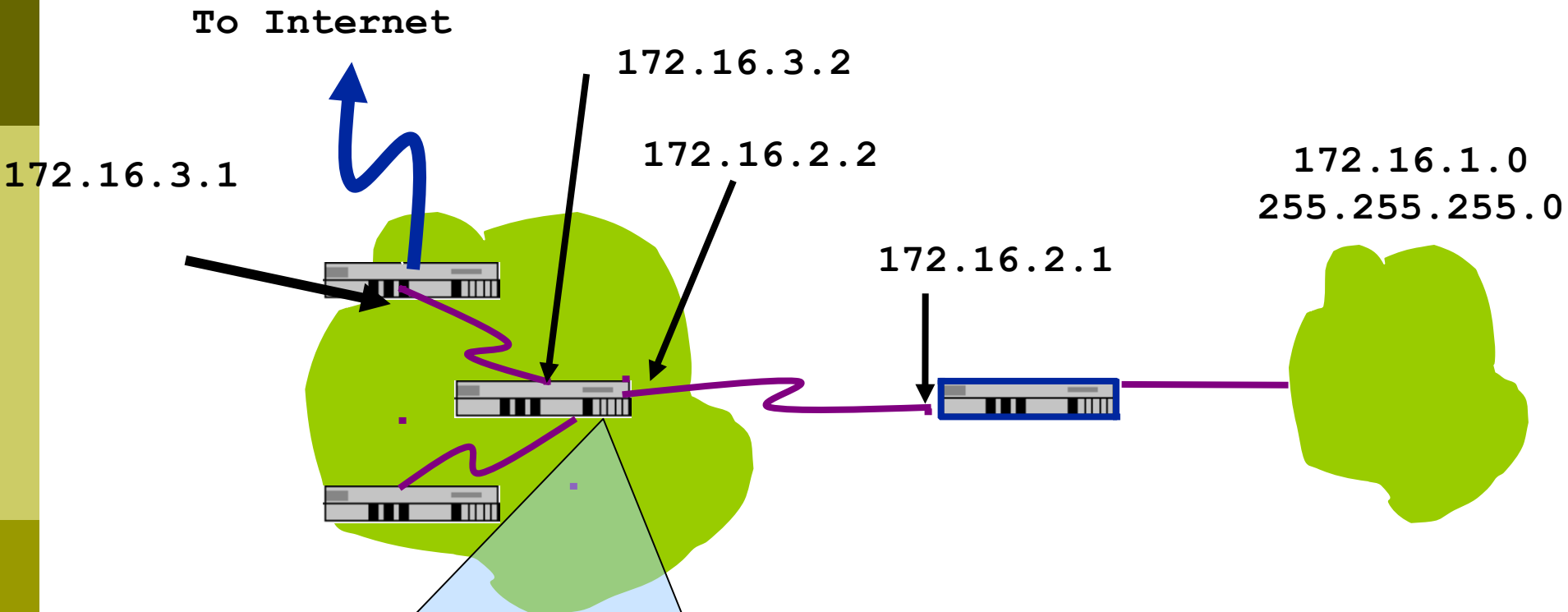

```
ip route 172.16.1.0 255.255.255.0 172.16.2.1 # STATIC
ip route 0.0.0.0 0.0.0.0 172.16.3.1 # DEFAULT
```

Classroom Network Layout

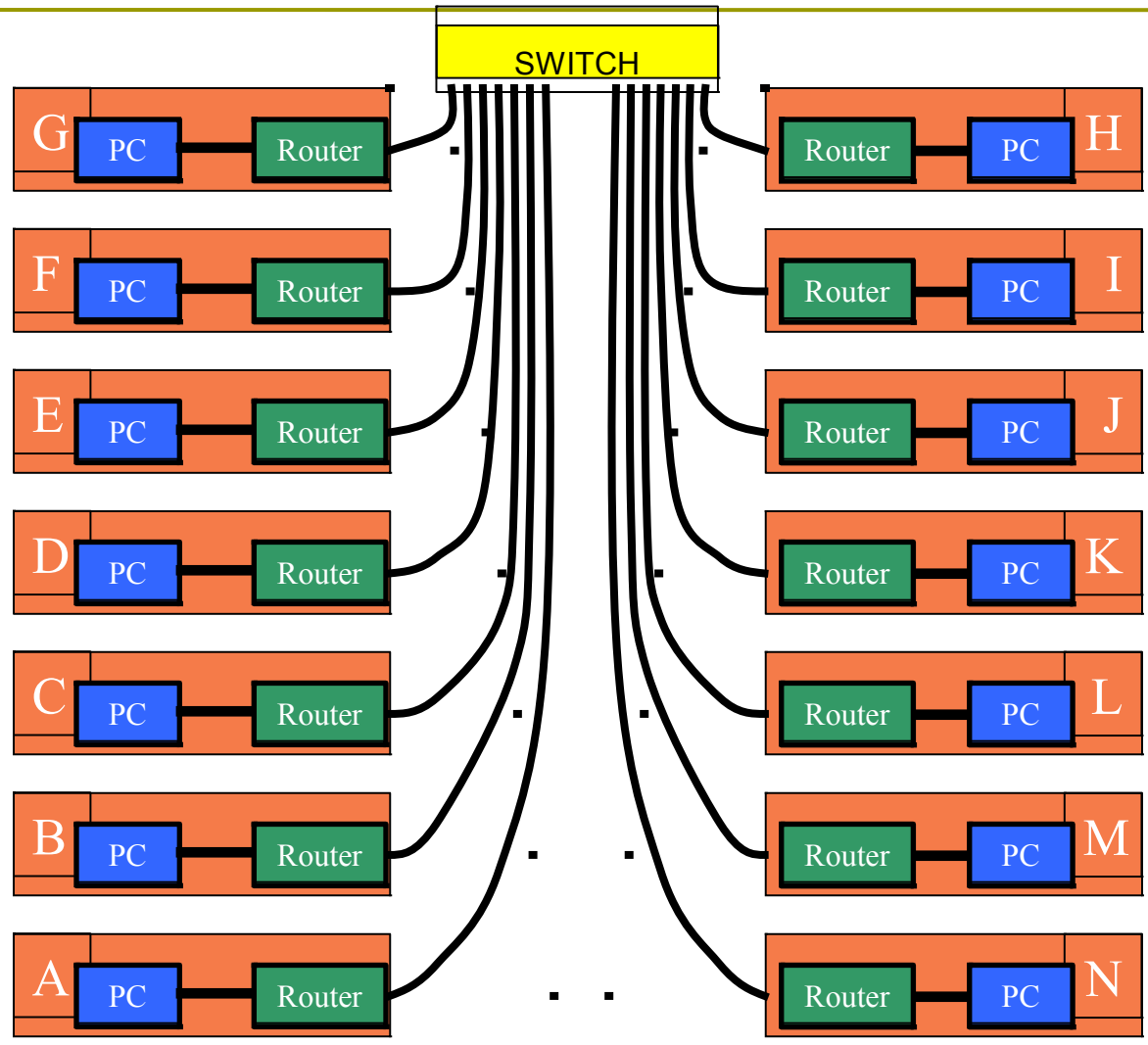

Exercise One



IPv4 Address Assignments

SWITCH

N
197.4.12.240/28

M
197.4.12.224/28

L
197.4.12.208/28

K
197.4.12.192/28

J
197.4.12.176/28

I
197.4.12.160/28

H
197.4.12.144/28

.1
14

.13 .2

.12 .3

.11 .4

.10 .5

.9 .6

.8 .7

197.4.12.0/27

197.4.12.32/28

197.4.12.48/28

197.4.12.64/28

197.4.12.80/28

197.4.12.96/28

197.4.12.112/28

197.4.12.128/28

A

B

C

D

E

F

G

IPv4 Address Assignment

- ❑ You already have an IP address for your router's backbone link (A=.1, B=.2, ...)
- ❑ You have a /28 for your local network (PC and router connected back to back)
- ❑ Assign your own host addresses from your /28 to your local network.

FreeBSD Network Interface Configuration

❑ configure interface on Unix host

❑ `ifconfig em0 inet n.n.n.n netmask m.m.m.m`

(you need to be root to change the IP address)

- `em0` is the interface name
- `n.n.n.n` is IP address
- `m.m.m.m` is netmask

Connect PC to router console port

- ❑ Connect cable to console port on router, serial port on FreeBSD box
- ❑ Use the tip command to connect your keyboard and screen to the serial port
 - e.g. `bash$ tip com1`
- ❑ You may have to edit `/etc/remote`
- ❑ See man pages for `tip(1)` and `remote(5)`
 - HINT: to exit tip, type `~`.

Cisco Router Network Interface Configuration

- ❑ configure backbone interface on cisco router

```
conf t
```

```
interface fastethernet0/0
```

```
ip address n.n.n.n m.m.m.m
```

fastethernet0/0 is interface name

n.n.n.n is IP address

m.m.m.m is netmask

- ❑ Now configure the local interface on your router that connects to your PC (ie. Fa0/1). Use the IP address assignments that you made 3 slides ago.

Cisco Router Network Interface Configuration

- ❑ Cisco global config should always include:
`ip classless`
`ip subnet-zero`
`ip cef`

- ❑ Cisco interface config should usually include:
`no shutdown`
`no ip proxy-arp`
`no ip redirects`
`no ip directed-broadcast`

Forwarding Tables at this point in the exercise

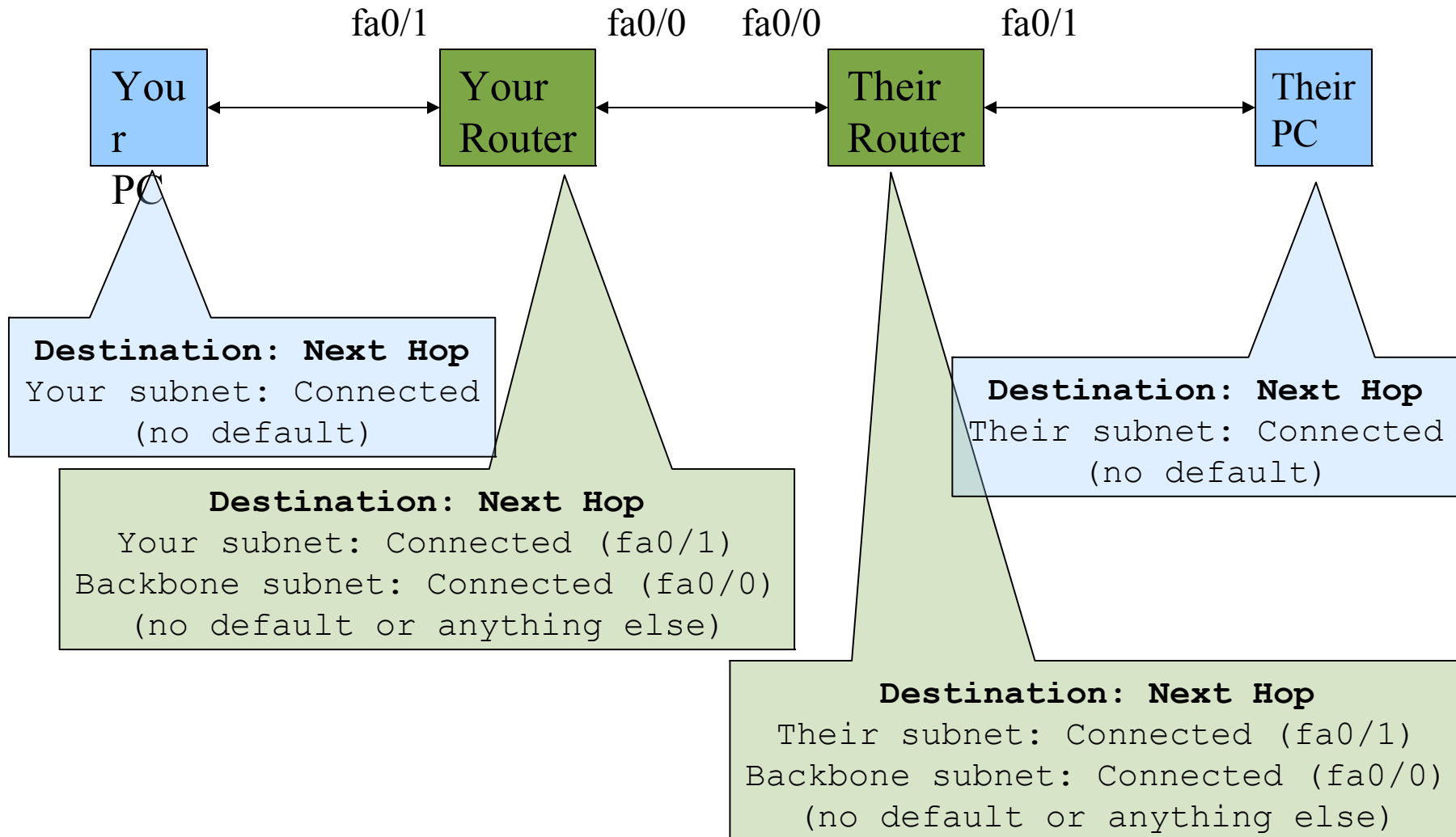

Test Connectivity

- ❑ PC can ping local interface of router
- ❑ Router can ping PC
- ❑ Router can ping other routers

- ❑ PC cannot ping backbone interface of router
- ❑ PC cannot ping other routers or other PCs
- ❑ Router cannot ping other PCs.

Configure a default route

- Add route on PC

```
route add default g.g.g.g
```

g.g.g.g is the IP address of your gateway, which will be the IP address of your router's interface to your subnet. (Don't use your router's backbone IP address.)

- Display forwarding table

```
netstat -rn
```

Forwarding Tables at this point in the exercise

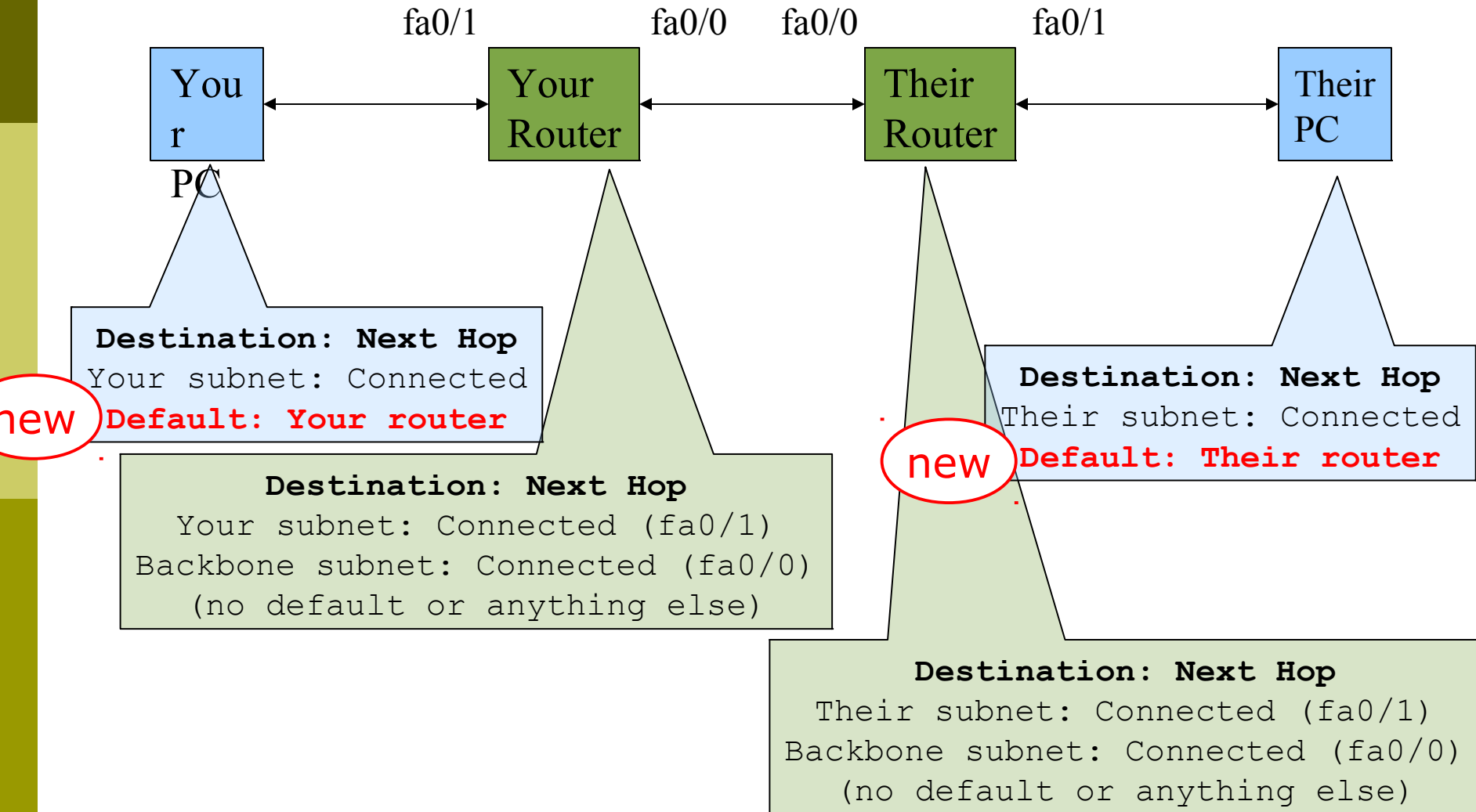

Test connectivity

- ❑ All PCs should now be able to reach the backbone IP address of their own routers.
- ❑ But, you still can't reach other PCs, or other routers.
 - why?

When you ping their router...

PING

src = Your PC

dst = Their Router (backbone address)

REPLY

src = Their Router (backbone address)

dst = Your PC

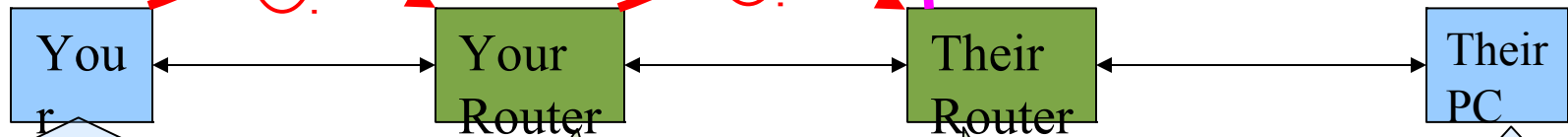

Destination: Next Hop

Your subnet: Connected

1 Default: Your router

Destination: Next Hop

Your subnet: Connected (fa0/1)

2 Backbone subnet: Connected (fa0/0)

(no default or anything else)

Destination: Next Hop

Their subnet: Connected

Default: Their router

Destination: Next Hop

Their subnet: Connected (fa0/1)

Backbone subnet: Connected (fa0/0)

(no default or anything else)

3 ???

Configure static routes for the remaining classroom desks

- ❑ On your router, add static routes to the other PCs, using their router's backbone IP addresses as the next-hop.

```
ip route n.n.n.n m.m.m.m g.g.g.g
```

n.n.n.n m.m.m.m is their subnet and netmask

g.g.g.g is their router's address on the backbone

- ❑ Do this for every PC/router cluster in the class
 - **There are A LOT of them.** Cut and paste?
- ❑ Consult the map earlier to obtain the PC/router local subnet, and the corresponding router backbone IP address.

Forwarding Tables at this point in the exercise

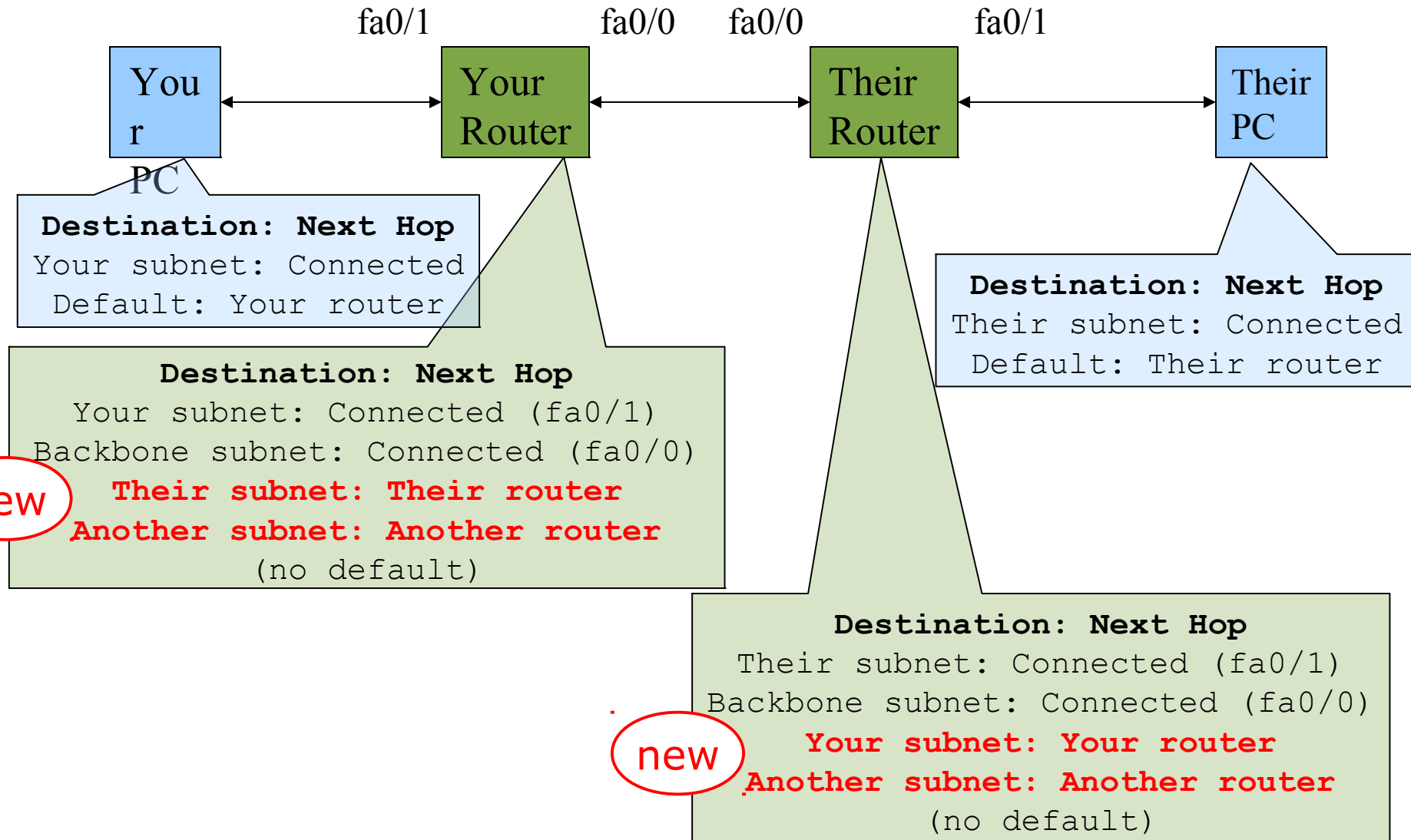

Test Connectivity

- ❑ All routers can reach all PCs
- ❑ All PCs can reach all backbone IP addresses
- ❑ All PCs can reach PCs in other rows
- ❑ Test with traceroute

When your PC pings their PC...

PING

src = Your PC

dst = Their PC

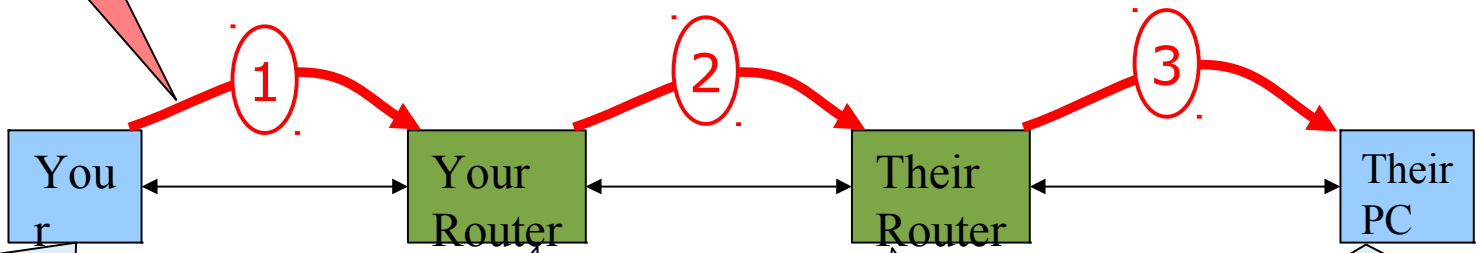

Destination: Next Hop

Your subnet: Connected

1 Default: Your router

Destination: Next Hop

Your subnet: Connected (fa0/1)

Backbone subnet: Connected (fa0/0)

2 Their subnet: Their router

Another subnet: Another router
(no default)

Destination: Next Hop

Their subnet: Connected

Default: Their router

Destination: Next Hop

3 Their subnet: Connected (fa0/1)

Backbone subnet: Connected (fa0/0)

Your subnet: Your router

Another subnet: Another router
(no default)

... and the reply from their PC

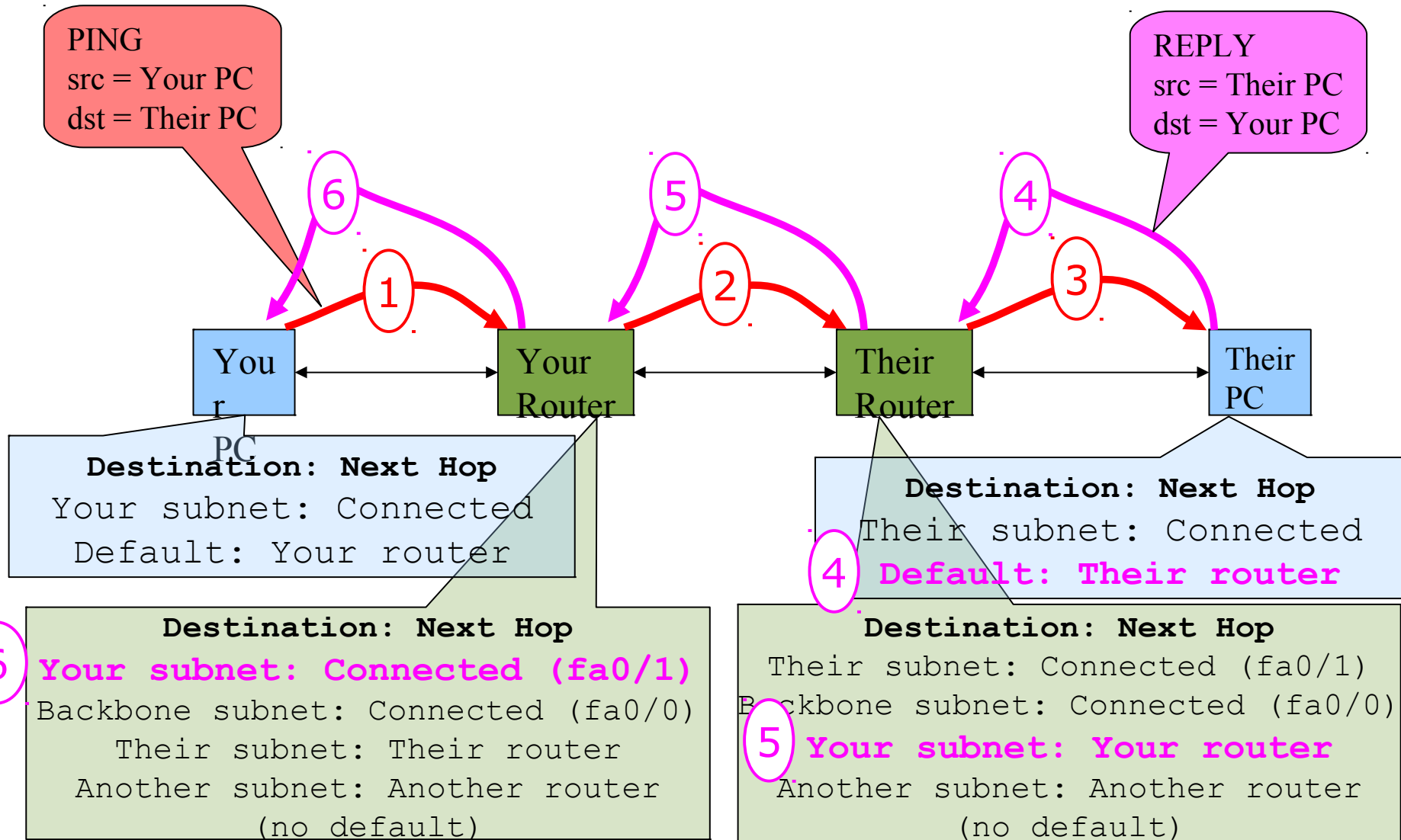

Static Exercise using IPv6

- ❑ Now let's repeat this exercise using IPv6 addressing
- ❑ Consult addressing plan for IPv6 addresses
 - Link between router and PC gets a /60
 - ❑ Group A use 2001:43f8:220:10::/60
 - ❑ Group B use 2001:43f8:220:20::/60
 - ❑ etc
 - Backbone is numbered from 2001:43f8:220:0::/64
 - Group A use 2001:43f8:220:0::1/64
 - Group B use 2001:43f8:220:0::2/64

Big Hint!

- ❑ If you are not using COPY/PASTE or the TFTP method to upload your config, you are wasting a lot of your time!

IPV6 Address Assignments

SWITCH

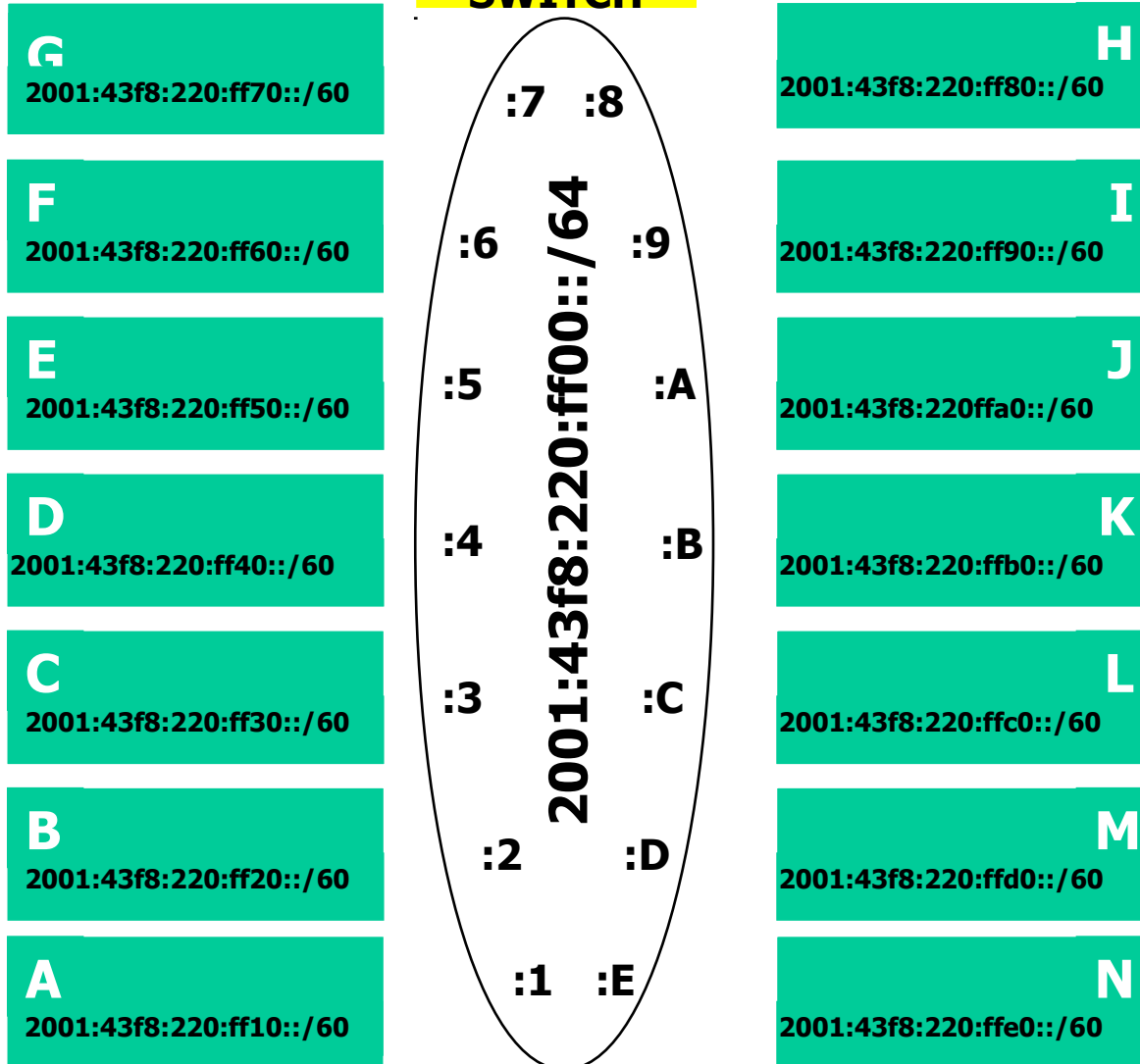

FreeBSD Network Interface Configuration

□ configure interface on Unix host
`ifconfig em0 inet6 n:n:n:n/m`

em0 is interface name

n:n:n:n is IPv6 address

m is netmask

Cisco Router Network Interface Configuration

- ❑ Configure the backbone interface on your router

```
conf t
```

```
ipv6 unicast-routing
```

```
interface fastethernet0/0
```

```
  ipv6 address n:n:n:n/m
```

fastethernet0/0 is interface name

n:n:n:n is IPv6 address

m is netmask

- ❑ Now configure local (lan-facing) interface on your router too.

Cisco Router Network Interface Configuration

- ❑ Cisco ipv6 global config should always include:

no ipv6 source-route

ipv6 cef

- ❑ Cisco interface config should additionally include:

no ipv6 redirects

Configure a default route

□ Add route on PC

```
route add -inet6 default g:g:g:g
```

- g:g:g:g is IPv6 address of gateway (which is on Cisco router)
- -inet6 tells FreeBSD that this is an IPv6 route

□ Display forwarding table

```
netstat -rn
```

Configure static routes for the remaining classroom desks

- ❑ On your router, add static routes to the other clusters, similar to how you did for ipv4.
 - next hop is backbone interface of other row's router

```
ipv6 route n:n:n:n/m g:g:g:g
```

- ❑ Repeat several times until complete

Test Connectivity

- ❑ All routers can reach all PCs
- ❑ All PCs can reach all backbone IP addresses
- ❑ All PCs can reach PCs in other rows
- ❑ Test with traceroute

Exercise Two



IPv4 Address Assignments

SIE Router
197.4.12.30/27

SWITCH

G

197.4.12.128/28

F

197.4.12.112/28

E

197.4.12.96/28

D

197.4.12.80/28

C

197.4.12.64/28

B

197.4.12.48/28

A

197.4.12.32/28

.7 .8

.6

.9

.5

.10

.4

.11

.3

.12

.2

.13

.1 .30

197.4.12.0/27

H

197.4.12.144/28

I

197.4.12.160/28

J

197.4.12.176/28

K

197.4.12.192/28

L

197.4.12.208/28

M

197.4.12.224/28

Lab router

IPv6 Address Assignments

G 2001:43f8:220:ff70::/60
F 2001:43f8:220:ff60::/60
E 2001:43f8:220:ff50::/60
D 2001:43f8:220:ff40::/60
C 2001:43f8:220:ff30::/60
B 2001:43f8:220:ff20::/60
A 2001:43f8:220:ff10::/60

SWITCH

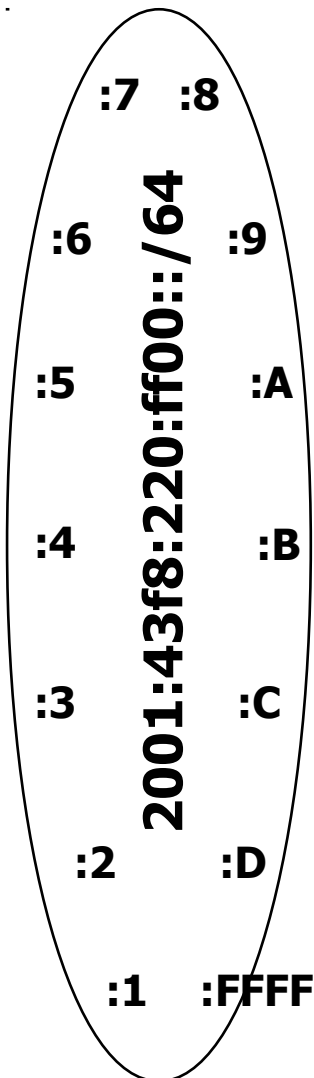

SIE Router 2001:43f8:220::F/64

H 2001:43f8:220:ff80::/60
I 2001:43f8:220:ff90::/60
J 2001:43f8:220:ffa0::/64
K 2001:43f8:220:ffb0::/60
L 2001:43f8:220:ffc0::/60
M 2001:43f8:220:ffd0::/60
Lab router

Configure static routes to classroom router

- ❑ On your router, remove all static routes

```
no ip route n.n.n.n m.m.m.m g.g.g.g
```

- ❑ Repeat until complete

Add routes to all other groups' blocks

```
ip route n.n.n.n m.m.m.m g.g.g.g
```

- ❑ Add a default route point to the SIE classroom router

- (next hop is backbone IP address of the SIE router)

```
ip route 0.0.0.0 0.0.0.0 g.g.g.g
```

- ❑ Do the same for IPv6:

```
no ipv6 route n:n:n:n/m g:g:g:g
```

```
ipv6 route n:n:n:n/m g:g:g:g
```

```
ipv6 route ::/0 g:g:g:g
```

Test Connectivity

- ❑ All routers can reach all PCs
- ❑ All PCs can reach all backbone IP addresses
- ❑ All PCs can reach PCs in other rows
- ❑ Test with traceroute
 - Test both IPv4 & IPv6

- ❑ How is this working?
 - All static routes have been added to the classroom router.

Edit FreeBSD's `/etc/rc.conf` file

- ❑ On production machines, add lines to `/etc/rc.conf` to preserve network settings on reboot

```
hostname="porcupine.tomato.example"  
ifconfig_em0="inet X.X.X.X netmask Y.Y.Y.Y"  
ipv6_ifconfig_em0="X:X:X:X prefixlen 64"  
defaultrouter="G.G.G.G"  
ipv6_defaultrouter="G:G:G:G"
```

- ❑ See `/etc/default/rc.conf` for more information

Static Routing Exercise



The End