

IPv6 Addressing & Routing Protocols



AfNOG 2011 AR-E Workshop

Topics

- Addressing plans for IPv6
- Configuring IPv6 in IOS
- IPv6 Routing Protocols

Addressing



Where to get IPv6 addresses

- Your upstream ISP
- Africa
 - AfriNIC – <http://www.afrinic.net>
- Asia and the Pacific
 - APNIC – <http://www.apnic.net>
- North America
 - ARIN – <http://www.arin.net>
- Latin America and the Caribbean
 - LACNIC – <http://www.lacnic.net>
- Europe and Middle East
 - RIPE NCC – <http://www.ripe.net/info/ncc>

Internet Registry Regions



Getting IPv6 address space

- Become a member of your Regional Internet Registry and get your own allocation
 - Require a plan for a year ahead
 - General allocation policies are outlined in RFC2050, more specific details for IPv6 are on the individual RIR website

or

- Take part of upstream ISP's PA space
- Use 6to4 is not recommended
 - Is now being actively discouraged due to serious operational problems
- There is plenty of IPv6 address space
 - The RIRs require high quality documentation

Getting IPv6 address space

- From the RIR
 - Receive a /32 (or larger if you will have more than 65k /48 assignments)
- From your upstream ISP
 - Get one /48 from your upstream ISP
 - More than one /48 if you have more than 65k subnets
- Use 6to4 (not recommended)
 - Take a single public IPv4 /32 address
 - 2002:<ipv4 /32 address>::/48 becomes your IPv6 address block, giving 65k subnets
 - Requires a 6to4 gateway
 - Read <http://datatracker.ietf.org/doc/draft-ietf-v6ops-6to4-to-historic>

Addressing Plans – ISP Infrastructure

- ❑ ISPs should receive /32 from their RIR
- ❑ Address block for router loop-back interfaces
 - Generally number all loopbacks out of **one** /64
 - /128 per loopback
- ❑ Address block for infrastructure
 - /48 allows 65k subnets
 - /48 per region (for the biggest networks)
 - /48 for whole backbone (for the majority of networks)
 - Summarise between sites if it makes sense

Addressing Plans – ISP Infrastructure

- What about LANs?
 - /64 per LAN
- What about Point-to-Point links?
 - Expectation is that /64 is used
 - /127s and /126s are being used
 - <http://datatracker.ietf.org/doc/draft-6man-prefixlen-p2p>
 - Mobile IPv6 Home Agent discovery won't work (doesn't matter on PtP links)
 - /112s are being used
 - Leaves final 16 bits free for node IDs
 - Some discussion about /80s, /96s and /120s too

Addressing Plans – Customer

- Customers get **one** /48
 - Unless they have more than 65k subnets in which case they get a second /48 (and so on)
 - Several ISPs give small customers a /56 or a /60 and single LAN end-sites a /64
(This is another very active discussion area)
- Should not be reserved or assigned on a per PoP basis
 - ISP iBGP carries customer nets
 - Aggregation within the iBGP not required and usually not desirable
 - Aggregation in eBGP is very necessary

Addressing Plans – ISP Infrastructure

Phase One

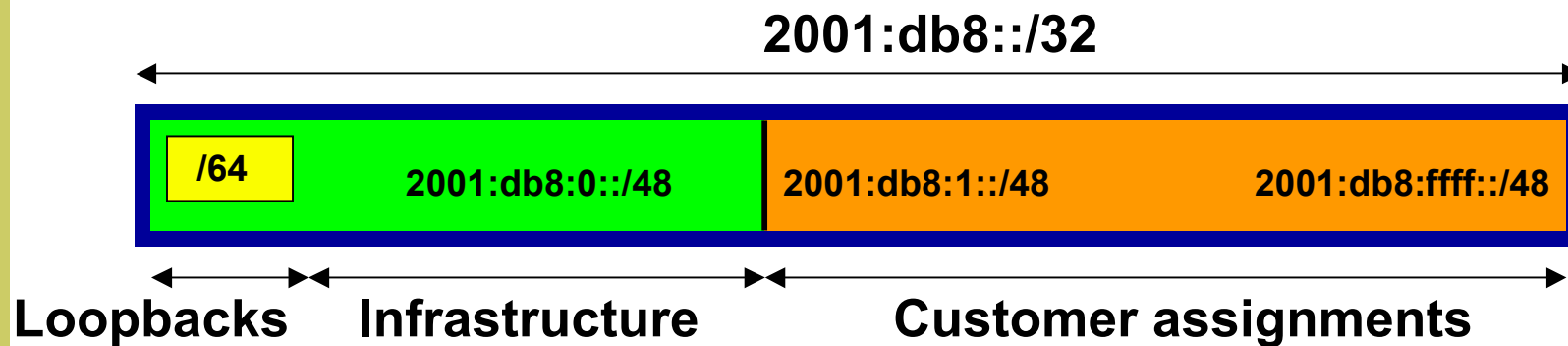

Phase Two - Second /32

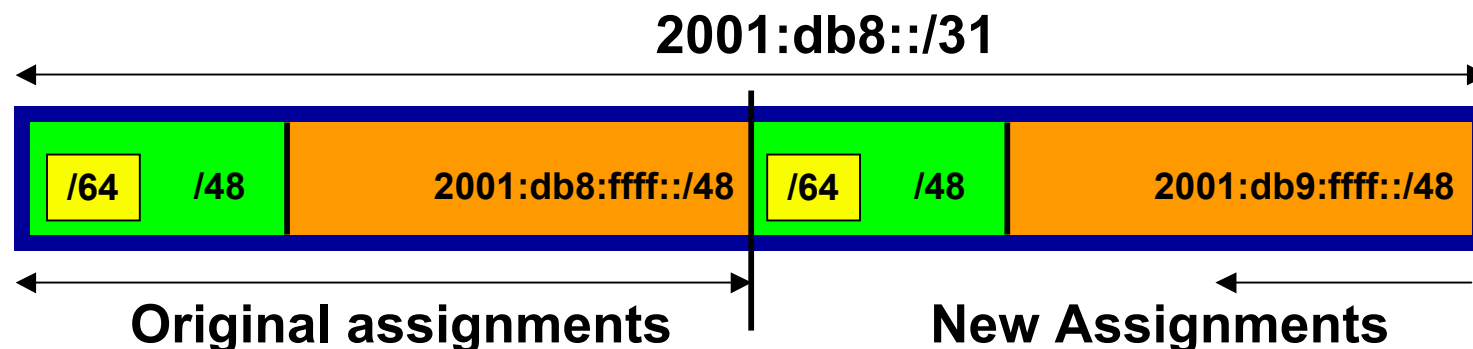

Addressing Plans

Planning

- Registries will usually allocate the next block to be contiguous with the first allocation
 - Minimum allocation is /32
 - Very likely that subsequent allocation will make this up to a /31
 - So plan accordingly

Addressing Plans (contd)

- Document infrastructure allocation
 - Eases operation, debugging and management
- Document customer allocation
 - Customers get /48 each
 - Prefix contained in iBGP
 - Eases operation, debugging and management
 - Submit network object to RIR Database

Addressing Tools

- Examples of IP address tools (which support IPv6 too):
 - IPAT nethead.de/index.php/ipat
 - ipv6gen techie.devnull.cz/ipv6/ipv6gen/
 - sipcalc www.routemeister.net/projects/sipcalc/
 - freeipdb home.globalcrossing.net/~freeipdb/

Initial IPv6 Configuration for IOS



IPv6 Configuration on Cisco IOS

- To enable IPv6 the following global command should be entered:

```
Router(config)# ipv6 unicast-routing
```

- Also enable IPv6 CEF (not on by default):

```
Router(config)# ipv6 cef
```

- Also disable IPv6 Source Routing (enabled by default):

```
Router(config)# no ipv6 source-routing
```

IPv6 Configuration

- ❑ To configure a global or unique-local IPv6 address the following interface command should be entered:

```
Router(config-if)# ipv6 address X:X..X:X/prefix
```

- ❑ To configure an EUI-64 based IPv6 address the following interface command should be entered:

```
Router(config-if)# ipv6 address X:X::/prefix eui-64
```

- This is not useful on a router and is not recommended

IPv6 Configuration

- Link-local address:
 - Enabling IPv6 on an interface using:
`Router(config-if)# ipv6 enable`
 - will result in a link-local IPv6 address being constructed automatically
 - FE80:: is concatenated with the Interface ID to give:
 - FE80::interface-id
- Configuring an IPv6 address (whether global or unique-local) will also result in a link-local IPv6 address being created

IPv6 Configuration

```
Router1# conf t
Router1(config)# ipv6 unicast-routing
Router1(config)# ipv6 cef
Router1(config)# int fast 0/0
Router1(config-int)# ipv6 enable
Router1(config-int)# ^Z
```

```
Router1#sh ipv6 interface fast 0/0
FastEthernet0/0 is up, line protocol is up
  IPv6 is enabled, link-local address is FE80::A8B9:C0FF:FE00:F11D
  No global unicast address is configured
  Joined group address(es):
    FF02::1
    FF02::2
    FF02::1:FF00:F11D
  MTU is 1500 bytes
  ICMP error messages limited to one every 100 milliseconds
  ICMP redirects are enabled
```

IPv6 Configuration – EUI64

```
Router1#sh ipv6 interface fast 0/0
FastEthernet0/0 is up, line protocol is up
  IPv6 is enabled, link-local address is FE80::A8B9:C0FF:FE00:F11D
  Global unicast address(es):
    2001:DB8::A8B9:C0FF:FE00:F11D, subnet is 2001:DB8::/64 [EUI]
  Joined group address(es):
    FF02::1
    FF02::2
    FF02::1:FF00:F11D
  MTU is 1500 bytes
  ICMP error messages limited to one every 100 milliseconds
  ICMP redirects are enabled
  ND DAD is enabled, number of DAD attempts: 1
  ND reachable time is 30000 milliseconds
  ND advertised reachable time is 0 milliseconds
  ND advertised retransmit interval is 0 milliseconds
  ND router advertisements are sent every 200 seconds
  ND router advertisements live for 1800 seconds
  Hosts use stateless autoconfig for addresses.
```

IPv6 Configuration – Static

```
Router1#sh ipv6 int fast 0/0
FastEthernet0/0 is up, line protocol is up
  IPv6 is enabled, link-local address is FE80::A8B9:C0FF:FE00:F11D
  Global unicast address(es):
    2001:DB8::2, subnet is 2001:DB8::/64
  Joined group address(es):
    FF02::1
    FF02::2
    FF02::1:FF08:2
    FF02::1:FE00:F11D
  ICMP error messages limited to one every 100 milliseconds
  ICMP redirects are enabled
  ND DAD is enabled, number of DAD attempts: 1
  ND reachable time is 30000 milliseconds
  ND advertised reachable time is 0 milliseconds
  ND advertised retransmit interval is 0 milliseconds
  ND router advertisements are sent every 200 seconds
  ND router advertisements live for 1800 seconds
  Hosts use stateless autoconfig for addresses.
```

Routing Protocols



Static Routing

- ❑ Syntax is:

- `ipv6 route ipv6-prefix/prefix-length {ipv6-address | interface-type interface-number} [administrative-distance]`

- ❑ Static Route

```
ipv6 route 2001:DB8::/64 2001:DB8:0:ABCD::1 150
```

- Routes packets for network `2001:db8::/64` to a networking device at `2001:DB8:0:ABCD::1` with an administrative distance of 150

Default Routing Example

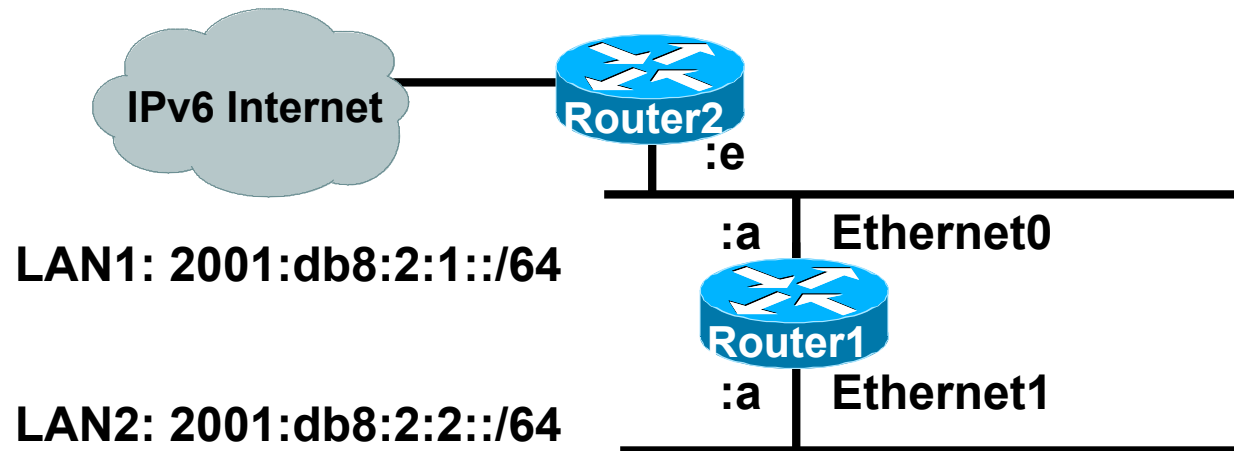

```
ipv6 unicast-routing
!  
interface Ethernet0  
  ipv6 address 2001:db8:2:1::a/64  
!  
interface Ethernet1  
  ipv6 address 2001:db8:2:2::a/64  
!  
ipv6 route ::/0 2001:db8:2:1::e
```

Default Route
to Router2

Dynamic Routing Protocols in IPv6

- Dynamic Routing in IPv6 is unchanged from IPv4:
 - IPv6 has 2 types of routing protocols: IGP and EGP
 - IPv6 still uses the longest-prefix match routing algorithm
- IGP
 - RIPng (RFC 2080)
 - Cisco EIGRP for IPv6
 - OSPFv3 (RFC 5340)
 - Integrated IS-ISv6 (RFC 5308)
- EGP
 - MP-BGP4 (RFC 4760 and RFC 2545)

Configuring Routing Protocols

- ❑ Dynamic routing protocols require router-id
 - Router-id is a 32 bit integer
 - IOS auto-generates these from loopback interface address if configured, else highest IPv4 address on the router
 - **Most ISPs will deploy IPv6 dual stack** – so router-id will be automatically created
- ❑ Early adopters choosing to deploy IPv6 in the total absence of any IPv4 addressing need to be aware:
 - Router-id needs to be manually configured:

```
ipv6 router ospf 100
  router-id 10.1.1.4
```

RIPng

- For the ISP industry, simply don't go here
- ISPs do not use RIP in any form unless there is absolutely no alternative
 - And there usually is
- RIPng was used in the early days of the IPv6 test network
 - Sensible routing protocols such as OSPF and BGP rapidly replaced RIPng when they became available

EIGRP for IPv6

- ❑ Cisco EIGRP has had IPv6 protocol support added
 - Just another protocol module (IP, IPX, AppleTalk) with three new TLVs:
 - ❑ IPv6_REQUEST_TYPE (0X0401)
 - ❑ IPv6_METRIC_TYPE (0X0402)
 - ❑ IPv6_EXTERIOR_TYPE (0X0403)
 - Router-ID is still 32-bit, protocol is still 88
- ❑ Uses similar CLI to existing IPv4 protocol support
- ❑ Easy deployment path for existing IPv4 EIGRP users
- ❑ In Cisco IOS Release 12.4 onwards

EIGRP for IPv6

□ Some differences:

- Hellos are sourced from the link-local address and destined to FF02::A (all EIGRP routers). This means that neighbors do not have to share the same global prefix (with the exception of explicitly specified neighbours where traffic is unicasted).
- Automatic summarisation is disabled by default for IPv6 (unlike IPv4)
- No split-horizon in the case of EIGRP for IPv6 (because IPv6 supports multiple prefixes per interface)

EIGRP for IPv6—Configuration & Display

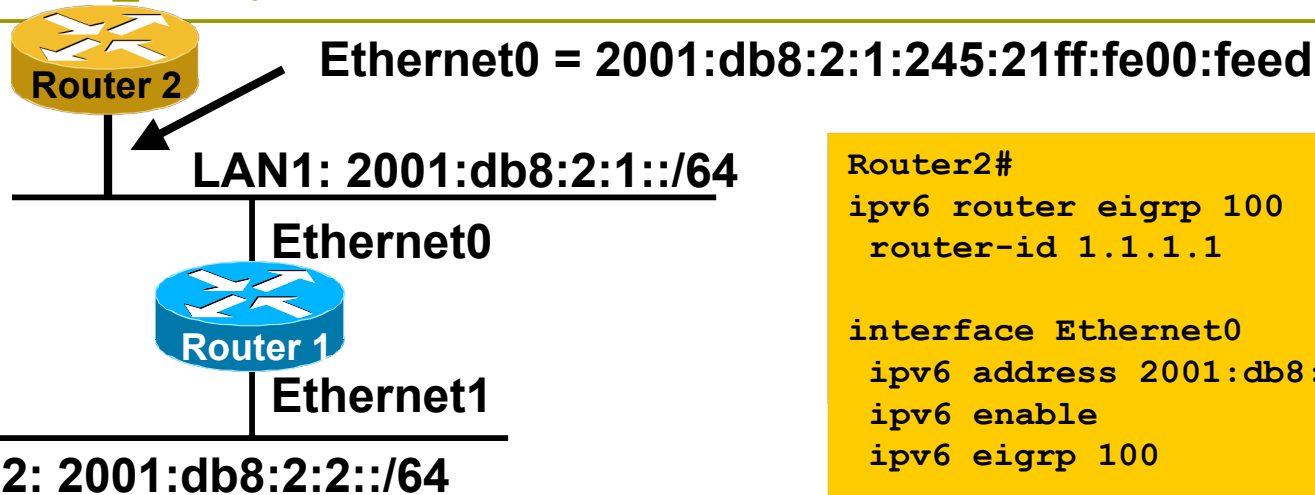

```
Router2#
ipv6 router eigrp 100
router-id 1.1.1.1

interface Ethernet0
ipv6 address 2001:db8:2:1::/64 eui-64
ipv6 enable
ipv6 eigrp 100
```

```
Router1#show ipv6 eigrp neighbor
IPv6-EIGRP neighbors for process 100
H Address Interface Hold Uptime SRTT RTO Q Seq
(sec) (ms) Cnt Num
0 FE80::245:21ff:fe00:feed E0 14 00:01:43 1 4500 0 1
```

```
Router1#show ipv6 eigrp topology all links
IPv6-EIGRP Topology Table for AS(100)/ID(1.1.1.1)
Codes: P - Passive, A - Active, U - Update, Q - Query, R - Reply,
r - reply Status, s - sia Status
P 2001:db8:2:1::/64, 1 successors, FD is 28160, serno 1
via Connected, Ethernet0
via FE80::245:21ff:fe00:feed (30720/28160), Ethernet0
```

Neighbour Identified by Link-Local Address

OSPFv3 overview

- ❑ OSPFv3 is OSPF for IPv6 (RFC 5340)
- ❑ Based on OSPFv2, with enhancements
- ❑ Distributes IPv6 prefixes
- ❑ Runs directly over IPv6
- ❑ Ships-in-the-night with OSPFv2

Differences from OSPFv2

- Runs over a link, not a subnet
 - Multiple instances per link
- Topology not IPv6 specific
 - Router ID
 - Link ID
- Standard authentication mechanisms
- Uses link local addresses
- Generalized flooding scope
- Two new LSA types

OSPFv3 configuration example

```
Router1#  
interface Ethernet0  
  ipv6 address 2001:db8:1:1::1/64  
  ipv6 ospf 1 area 0  
  
interface Ethernet1  
  ipv6 address 2001:db8:2:2::2/64  
  ipv6 ospf 1 area 1  
  
ipv6 router ospf 1  
  router-id 1.1.1.1
```

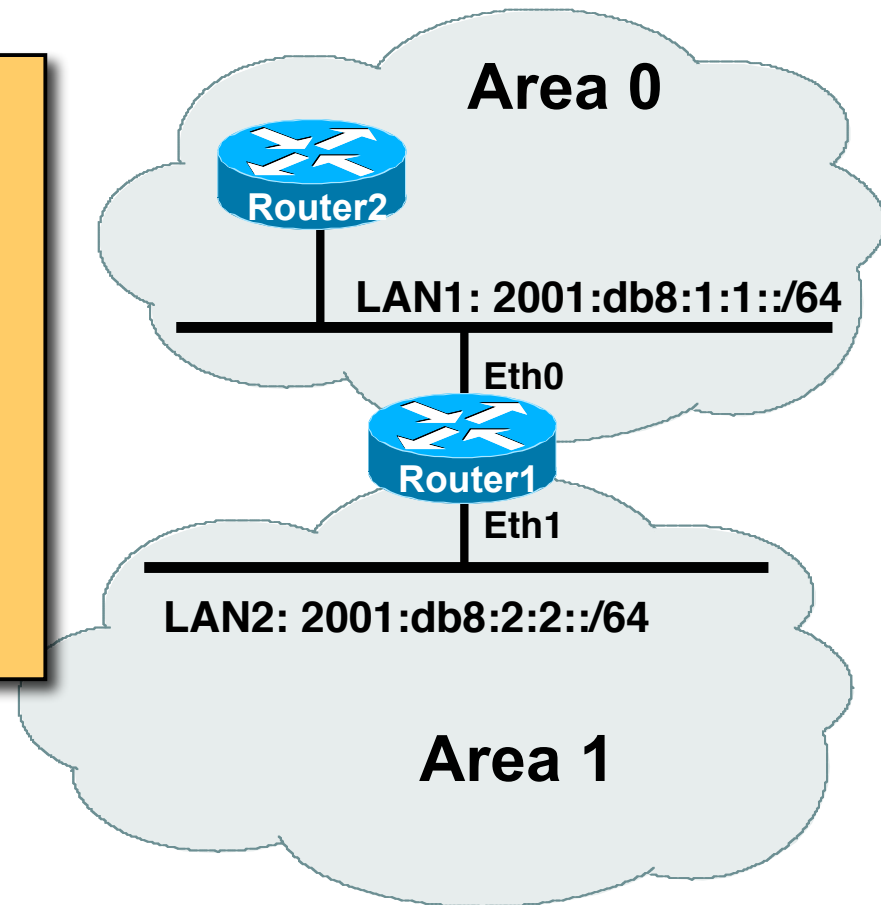

IS-IS Standards History

- ❑ IETF ISIS for Internets Working Group
- ❑ ISO 10589 specifies OSI IS-IS routing protocol for CLNS traffic
 - Tag/Length/Value (TLV) options to enhance the protocol
 - A Link State protocol with a 2 level hierarchical architecture.
- ❑ RFC 1195 added IP support, also known as Integrated IS-IS (I/IS-IS)
 - I/IS-IS runs on top of the Data Link Layer
 - Requires CLNP to be configured
- ❑ RFC5308 adds IPv6 address family support to IS-IS
- ❑ RFC5120 defines Multi-Topology concept for IS-IS
 - Permits IPv4 and IPv6 topologies which are not identical
 - Allows gradual roll out of IPv6 across backbone without impacting IPv4

IS-IS for IPv6

- ❑ 2 Tag/Length/Values added to introduce IPv6 routing
- ❑ IPv6 Reachability TLV (0xEC)
 - External bit
 - Equivalent to IP Internal/External Reachability TLV's
- ❑ IPv6 Interface Address TLV (0xE8)
 - For Hello PDUs, must contain the Link-Local address
 - For LSP, must only contain the non-Link Local address
- ❑ IPv6 NLPID (0x8E) is advertised by IPv6 enabled routers

Cisco IOS IS-IS dual stack configuration

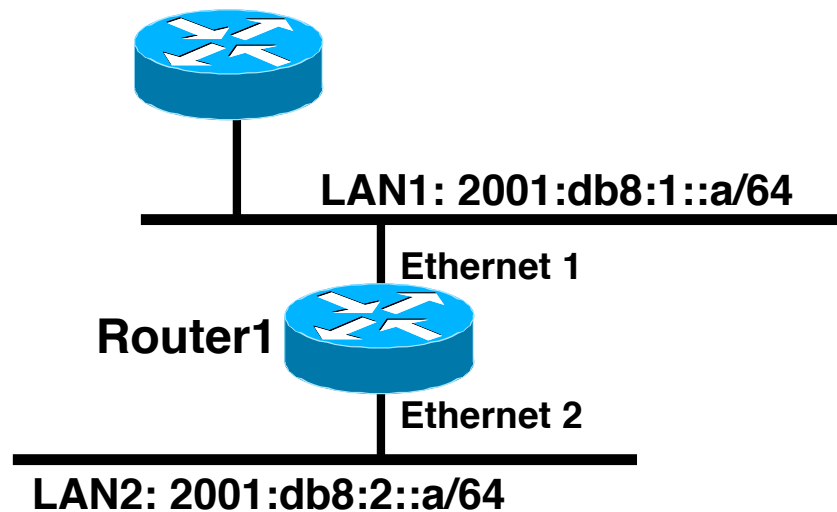

**Dual IPv4/IPv6 configuration.
Redistributing both IPv6 static routes
and IPv4 static routes.**

```
Router1#  
interface ethernet 1  
  ip address 10.1.1.1 255.255.255.0  
  ipv6 address 2001:db8:1::a/64  
  ip router isis  
  ipv6 router isis  
  
interface ethernet 2  
  ip address 10.2.1.1 255.255.255.0  
  ipv6 address 2001:db8:2::a/64  
  ip router isis  
  ipv6 router isis  
  
router isis  
  address-family ipv6  
    redistribute static  
  exit-address-family  
  net 42.0001.0000.0000.072c.00  
  redistribute static
```

Multi-Topology IS-IS extensions

- New TLVs attributes for Multi-Topology extensions.
 - Multi-topology TLV: contains one or more multi-topology ID in which the router participates. It is theoretically possible to advertise an infinite number of topologies. This TLV is included in IIH and the first fragment of a LSP.
 - MT Intermediate Systems TLV: this TLV appears as many times as the number of topologies a node supports. A MT ID is added to the extended IS reachability TLV type 22.
 - Multi-Topology Reachable IPv4 Prefixes TLV: this TLV appears as many times as the number of IPv4 announced by an IS for a given MT ID. Its structure is aligned with the extended IS Reachability TLV Type 236 and add a MT ID.
 - Multi-Topology Reachable IPv6 Prefixes TLV: this TLV appears as many times as the number of IPv6 announced by an IS for a given MT ID. Its structure is aligned with the extended IS Reachability TLV Type 236 and add a MT ID.
- Multi-Topology ID Values
 - Multi-Topology ID (MT ID) standardized and in use in Cisco IOS:
 - MT ID #0 – “standard” topology for IPv4/CLNS
 - MT ID #2 – IPv6 Routing Topology.

Multi-Topology ISIS configuration example

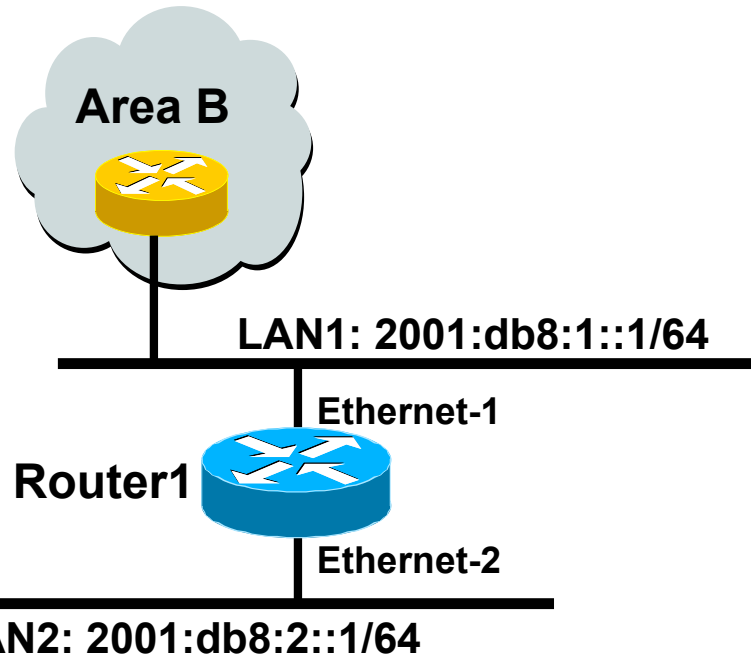

- ❑ The optional keyword **transition** may be used for transitioning existing IS-IS IPv6 single SPF mode to MT IS-IS
- ❑ Wide metric is mandated for Multi-Topology to work

```
Router1#
interface ethernet-1
 ip address 10.1.1.1 255.255.255.0
 ipv6 address 2001:db8:1::1/64
 ip router isis
 ipv6 router isis
 isis ipv6 metric 20

interface ethernet-2
 ip address 10.2.1.1 255.255.255.0
 ipv6 address 2001:db8:2::1/64
 ip router isis
 ipv6 router isis
 isis ipv6 metric 20

router isis
 net 49.0000.0100.0000.0000.0500
 metric-style wide
 !
 address-family ipv6
 multi-topology
 exit-address-family
```

Multi-Protocol BGP for IPv6 – RFC2545

- IPv6 specific extensions
 - Scoped addresses: Next-hop contains a global IPv6 address and/or potentially a link-local address
 - NEXT_HOP and NLRI are expressed as IPv6 addresses and prefix
 - Address Family Information (AFI) = 2 (IPv6)
 - Sub-AFI = 1 (NLRI is used for unicast)
 - Sub-AFI = 2 (NLRI is used for multicast RPF check)
 - Sub-AFI = 3 (NLRI is used for both unicast and multicast RPF check)
 - Sub-AFI = 4 (label)

A Simple MP-BGP Session

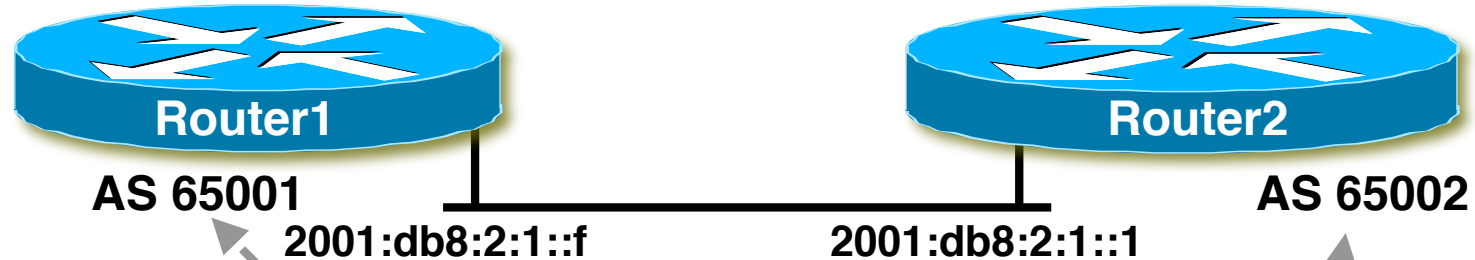

```
Router1#  
interface Ethernet0  
  ipv6 address 2001:db8:2:1::f/64  
!  
router bgp 65001  
  bgp router-id 10.10.10.1  
  no bgp default ipv4-unicast  
  neighbor 2001:db8:2:1::1 remote-as 65002  
  address-family ipv6  
    neighbor 2001:db8:2:1::1 activate  
    neighbor 2001:db8:2:1::1 prefix-list bgp65002in in  
    neighbor 2001:db8:2:1::1 prefix-list bgp65002out out  
  exit-address-family
```

Routing Protocols for IPv6

Summary

- ❑ Support for IPv6 in the major routing protocols
- ❑ More details for OSPF, ISIS and BGP in following presentations

IPv6 Addressing & Routing Protocols



AfNOG 2011 AR-E Workshop